

XGLO® & LightSystem®

Indoor/Outdoor LooseTube, B2_{ca}s_{1b}d₁a₁ - EMEA

Siemon LSOH-FR indoor/outdoor loose tube cables are ideal for campus and building backbones. Siemon fiber optic cables are offered in XGLO and LightSystem configurations supporting high-speed, applications such as Gigabit Ethernet, 10 Gigabit Ethernet and Fiber Channel. Siemon indoor/outdoor water blocking is primarily for dry duct applications, moisture and temporary water migration protection.

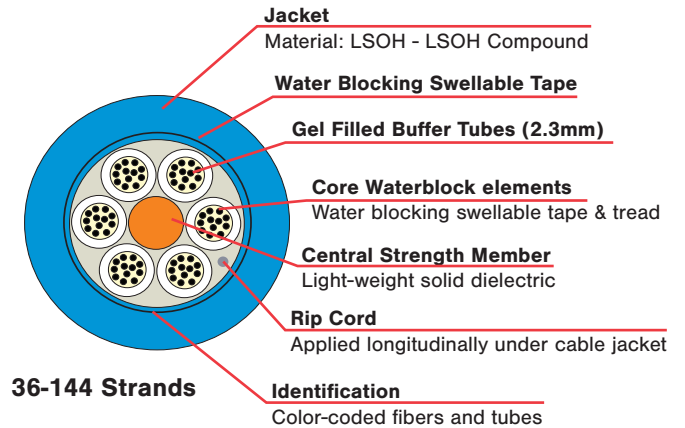
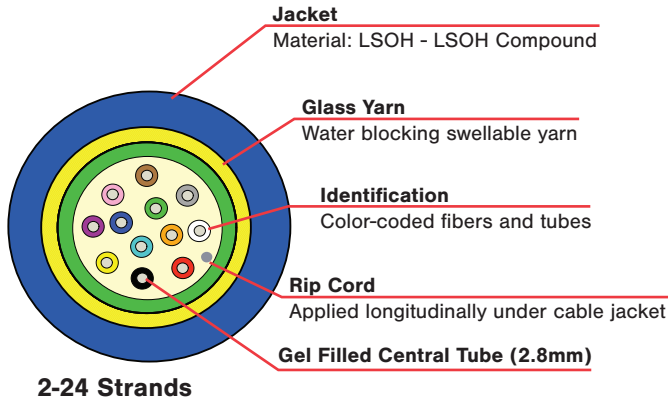

Note: The 2-24 strand cables feature a glass yarn design with a high tensile strength that provides a degree of rodent protection which is effective in many cases. The function of glass yarns differs from the other rodent protection materials such as a 100% metallic armour protection. The glass yarns provide a degree of protection because it is disagreeable and unpleasant for most rodents to gnaw the glass yarns.

Ordering Information

LightSystem Multimode 62.5/125 OM1,
XGLO Multimode 50/125 OM3, 50/125 OM4, Singlemode

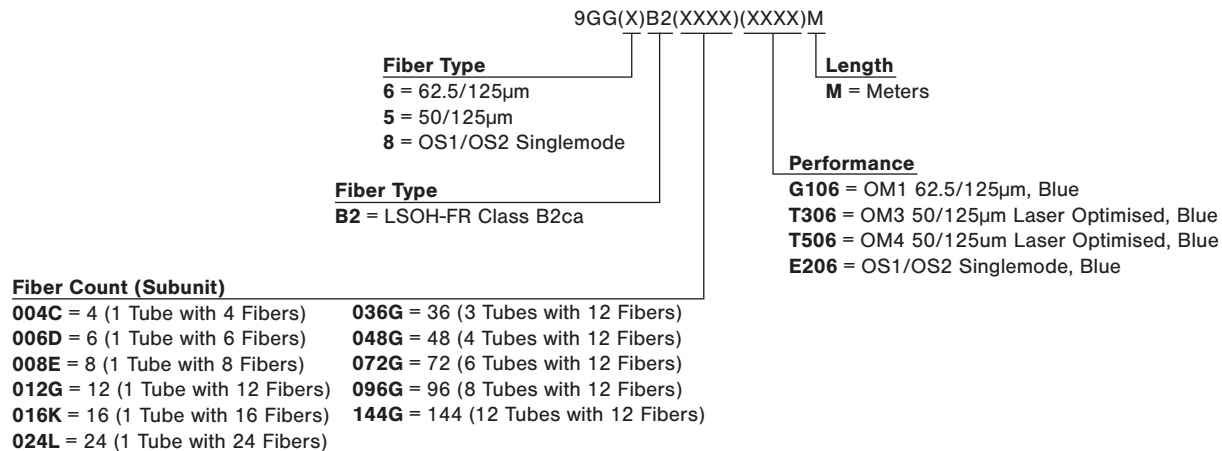

Standards Compliance

LIGHTSYSTEM MULTIMODE 62.5/125, OM1	XGLO 300 MULTIMODE 50/125, OM3	XGLO 550 MULTIMODE 50/125, OM4	XGLO SINGLEMODE, OS1/OS2
ISO/IEC 11801:2002 OM1 (62.5/125)	ISO/IEC 11801:2002 OM3	ISO/IEC 11801:2002 OM3	ISO/IEC 11801:Ed 2.0 Amendment:1:2008
ANSI/TIA-568.3-D	ANSI/TIA-568.3-D	ISO/IEC 11801:200 Ammendment 2 OM	ANSI/TIA-568.3-D
ANSI/TIA-598-D	ANSI/TIA-598-D	ANSI/TIA-568.3-D	ANSI/TIA-598-D
ANSI/TIA-492 AAAA	ANSI/TIA-492 AAAC	ANSI/TIA-598-D	ANSI/TIA-492 CAAB
Telcordia GR-409-CORE	IEC 60793-2-10 Fiber Type Ala.2	ANSI/TIA-492 AAAD	Telcordia GR-409-CORE
IEC 60794-6-10 (Water penetration F5B)	IEC 60794-6-10 (Water penetration F5B)	IEC 60793-2-10 Fiber Type A1a.3	ITU-T G.652 C/D
IEC 60332-1-2 Class	Telcordia GR-409-CORE	Telcordia GR-409-CORE	IEC 60794-6-10 (Water penetration F5B)
IEC 60332-3, IEC 60332-1-12 (Single Strand) IEC 60754-2 (Acid Gas) IEC 61034-2 (Smoke Density)	IEC 60332-1-2 Class	IEC 60794-6-10 (Water penetration F5B)	IEC 60332-1-2 Class
EN 50399 Class Eca, Dca Class Cca, s1a , d1, a1 Class B2ca, s1a , d1, a1	IEC 60332-3, IEC 60332-1-12 (Single Strand) IEC 60754-2 (Acid Gas) IEC 61034-2 (Smoke Density)	IEC 60332-1-2 Class	IEC 60332-3, IEC 60332-1-12 (Single Strand) IEC 60754-2 (Acid Gas) IEC 61034-2 (Smoke Density)
	EN 50399 Class Eca, Dca Class Cca, s1b , d1, a1 Class B2ca, s1b , d1, a1	IEC 60332-3, IEC 60332-1-12 (Single Strand) IEC 60754-2 (Acid Gas) IEC 61034-2 (Smoke Density)	EN 50399 Class Eca, Dca Class Cca, s1b , d1, a1 Class B2ca, s1b , d1, a1
		EN 50399 Class Eca, Dca Class Cca, s1b , d1, a1 Class B2ca, s1b , d1, a1	

Applications Support

APPLICATION	DISTANCE (M)	APPLICATION	DISTANCE (M)	APPLICATION	DISTANCE (M)	APPLICATION	DISTANCE (M)
10 GBASE-S (850 nm)	N/A	10 GBASE-S (850 nm)	300	10GBASE-S (850 nm)	300	10GBASE - L (1310 nm)	8000
62.5/125µm	26	10 GBASE-LX4 (1300 nm)	300	10GBASE-LX4 (1300 nm)	300	10GBASE- E (1550 nm)	30000
1000 BASE-S (850 nm)	N/A	1000BASE-S (850 nm)	1000	1000BASE-S (850 nm)	1000	10G Fiber Channel (Serial-1310 nm)	10000
62.5/125µm	275	1000 BASE-LX (1300 nm)	600	1000BASE-LX (1300 nm)	600	10G Fiber Channel (WDM -1310 nm)	10000
1000BASE-LX (1300 nm)	550	Fiber Channel 266 (1300 nm)	1500	Fiber Channel 266 (1300 nm)	1500	1000BASE-LX (1300 nm)	5000
Fiber Channel 266 (1300 nm)	1,500	ATM 622 (1300 nm)	500	ATM 622 (1300 nm)	500	Fiber Channel 266/1062 (1300 nm)	10000
ATM 622 (1300 nm)	500	ATM 155 (1300 nm)	2000	ATM 155 (1300 nm)	2000	ATM 52/155/622 (1300 nm)	15000
ATM 155 (1300 nm)	2000	ATM 52 (1300 nm)	3000	ATM 52 (1300 nm)	3000		
ATM 52 (1300 nm)	3000	FDD1 (Original-1300 nm)	2000	FDD1 (Original-1300 nm)	2000		
FDD1 (Original-1300 nm)	2000	100BASE -FX (1300 nm)	2000	100BASE -FX (1300 nm)	2000		
100BASE-FX (1300 nm)	2000						

LightSystem Gigabit Ethernet Fiber Optic Cable Product Information

MINIMUM PERFORMANCE PARAMETERS FOR LIGHTSYSTEM 62.5/125μM MULTIMODE FIBER

Fiber Type	Wavelength nm	Maximum Attenuation (dB/km)	Minimum Modal Bandwidth (MHz • km)	Guaranteed Gigabit Transmission Distance Meters (Feet)
62.5/125 (OM1)	850	3.5	200	275 (902)
	1300	1.0	500	550 (1804)

*The protocol pertinent to the transmission distance as noted is Gigabit Ethernet per IEEE 802.3:2005.

MINIMUM PERFORMANCE PARAMETERS FOR XGLO 50/125μM MULTIMODE FIBER

Fiber Type	Guaranteed Gigabit Transmission Distance (m)		Guaranteed 10 Gigabit Transmission Distance (m)		Minimum Bandwidth (MHz • km)		Maximum Attenuation (dB/km)	
	850 nm	1300 nm	850 nm†	1300 nm††	850 nm	1300 nm	850 nm	1300 nm
50/125 (OM3)	1000	600	300	300	RML - 2000 OFL - 1500	OFL - 500	3.0	1.0
50/125 (OM4)	1100	600	550	300	RML - 4700 OFL - 3500	OFL - 500	3.0	1.0

† 10GBASE-S †† 10GBASE-LX4

MINIMUM PERFORMANCE PARAMETERS FOR XGLO SINGLEMODE FIBER

Fiber Type	Wavelength (nm)	Maximum Attenuation (dB/km)
Singlemode (OS1/OS2)	1310	0.40
	1550	0.30

XGLO and LightSystem Indoor/Outdoor LooseTube (EMEA) Physical Specifications

PHYSICAL SPECIFICATIONS (ALL VALUES ARE NOMINAL)

Fiber Count	Nominal Cable Diameter mm	Maximum Pulling Tension Newtons		Nominal Net Weight kg/km	Minimum Bend Radius	
		Installation	Long Term		Installation	Long Term
2-24	7.5	3000	1000	90		
36	10.6	1800	600	103		
48	10.6	1800	600	105		
72	10.6	1800	600	115		
96	11.8	1800	600	145		
144	15.2	1800	600	240		

Fiber Count	Maximum Crush Resistance (N/mm)	Operation Temperature °C (°F)	Installation Temperature °C (°F)	Storage Temperature °C (°F)	Minimum Bend Radius	
					Installation	Long Term
2-24	30	-40 to 70 (-40 to 158)	-20 to 60 (-4 to 140)	-40 to 70 (-40 to 158)	20 x DIA	10 x DIA
36-144	20	-40 to 70 (-40 to 158)	-40 to 70 (-40 to 158)	-40 to 70 (-40 to 158)	20 x DIA	10 x DIA

Custom lengths and jacket colors are available upon request. Contact our Customer Service Department for more information.

Because we continuously improve our products, Siemon reserves the right to change specifications and availability without prior notice.

North America P: (1) 860 945 4200	Asia Pacific P: (61) 2 8977 7500	Latin America P: (571) 657 1950/51/52	Europe P: (44) 0 1932 571771	China P: (86) 215385 0303	India Middle East P: (971) 4 3689743
---	--	---	--	-------------------------------------	--

Siemon OEM Technologies
P: (1) 860 945 4213
www.siemon.com/OEM

WWW.SIEMON.COM

SS_XGLOInOut LooseTubeB2CAS1AD1A1-EMEA_RevC 5/22

