

# Accessory Shelves - Installation Instructions

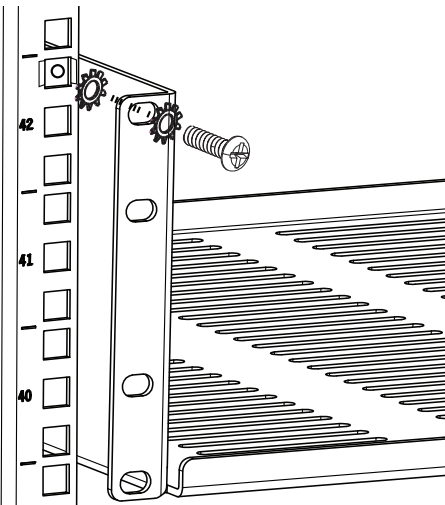
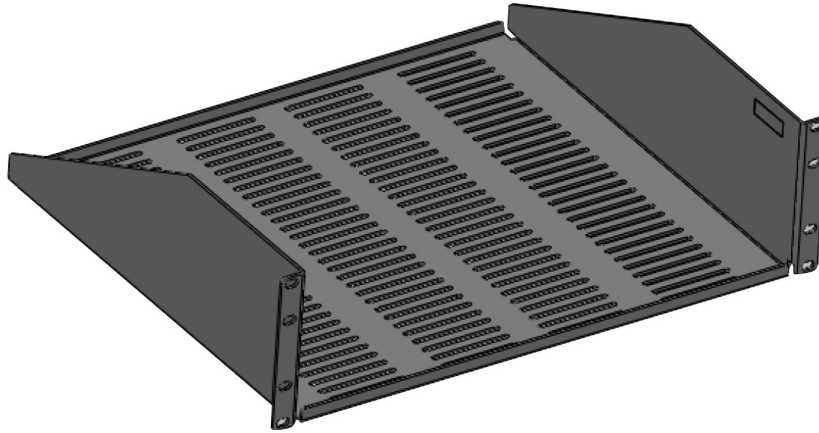

1. Safety Warning - Maximum weight load - 34 kg (75lbs).
2. Each shelf is provided with two star washers and one grounding screw.
3. Place one star washer in between shelf and cabinet rail and other star washer between shelf and ground screw.
4. Securely fasten ground screw to cabinet rail.

## To assist safe installations, comply with the following:

- A. Use caution when installing or modifying telecommunications circuits.
- B. Never touch uninsulated wire terminals unless the circuit has been disconnected.
- C. Never install this device in a wet location.
- D. Never install wiring during a lightning storm.

## Lors de l'installation, respectez les consignes de sécurité suivantes:

- A. Utiliser avec prudence lors de l'installation ou de la modification circuits de télécommunications.
- B. Ne jamais toucher les bornes de fil métallique non isolés sauf si le circuit a été débranché.
- C. Ne jamais installer cet appareil dans un endroit humide.
- D. Ne jamais installer pendant un orage.



**Global Headquarters**  
Watertown, Connecticut USA  
Tel: (1) 866-548-5814

For a complete listing of our global offices visit our web site