

# Angled TERA<sup>®</sup>-MAX<sup>®</sup> Patch Panel

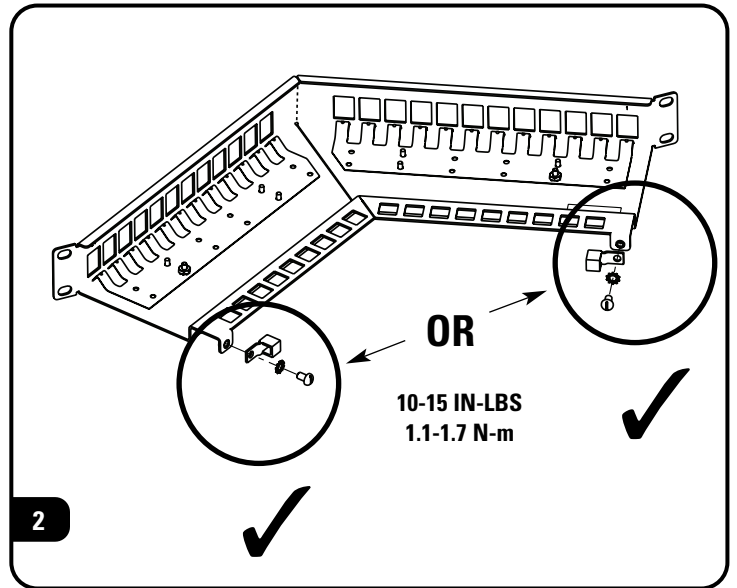

## TERA

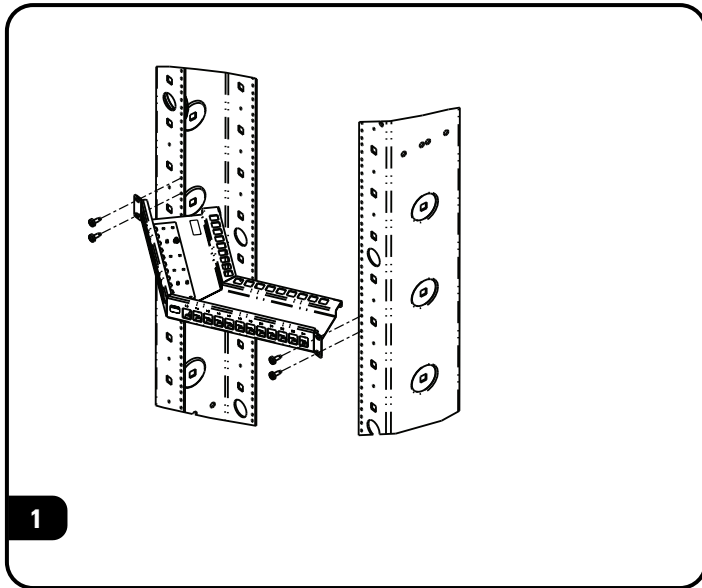
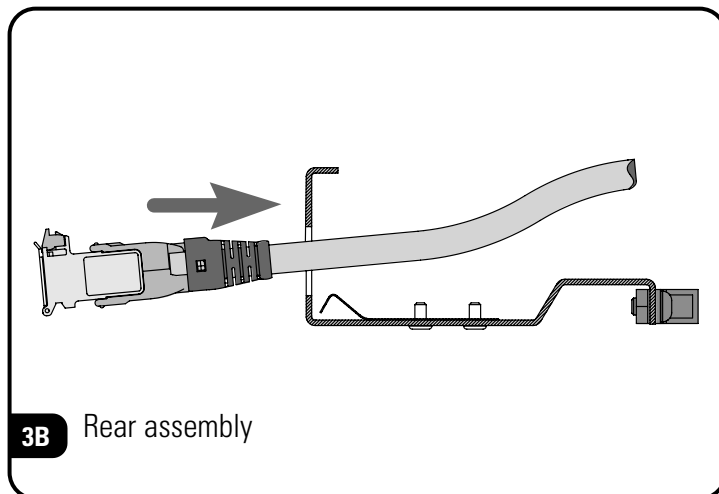
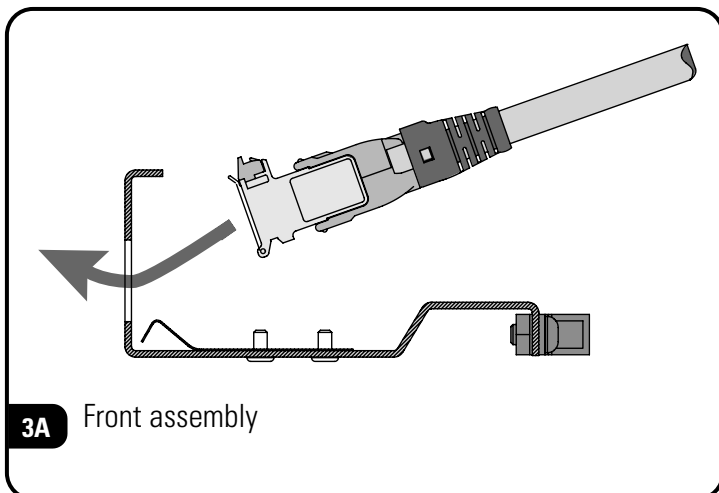

## MAX

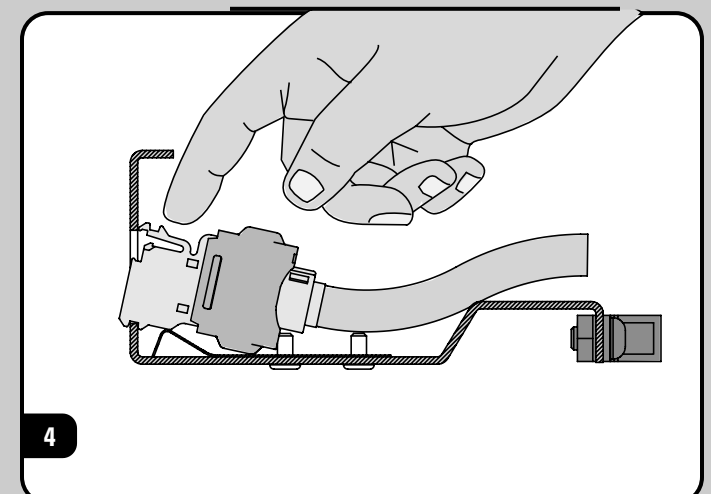
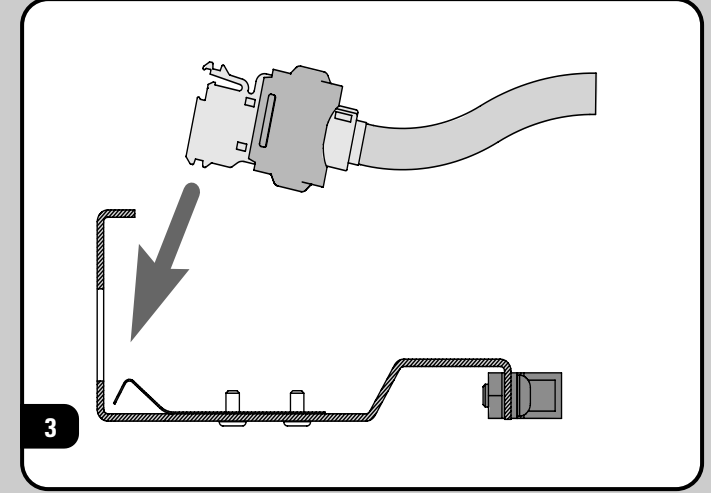

# Angled TERA® - MAX™ Patch Panel

## TERA

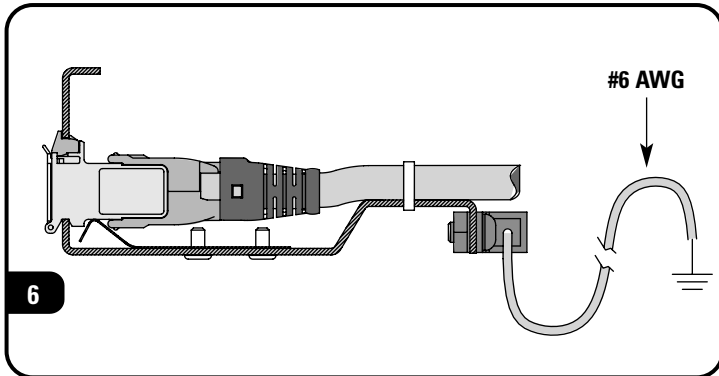
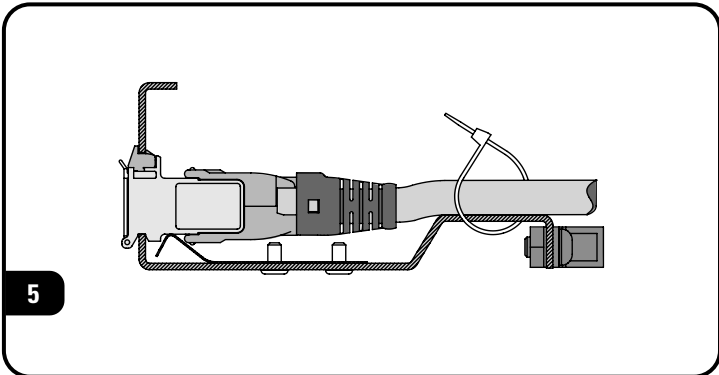
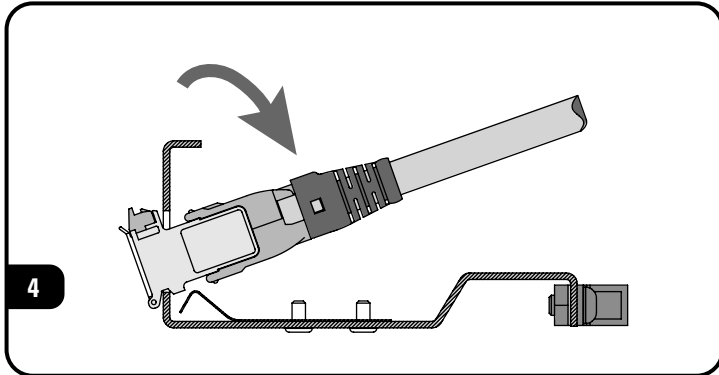

## MAX

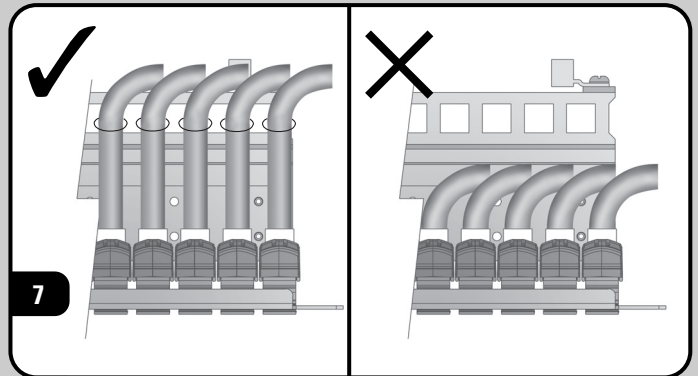
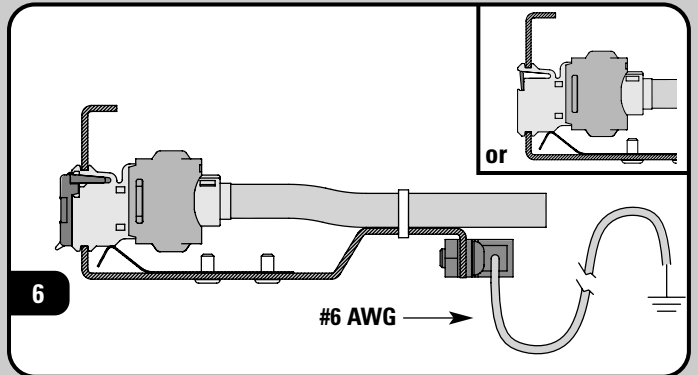
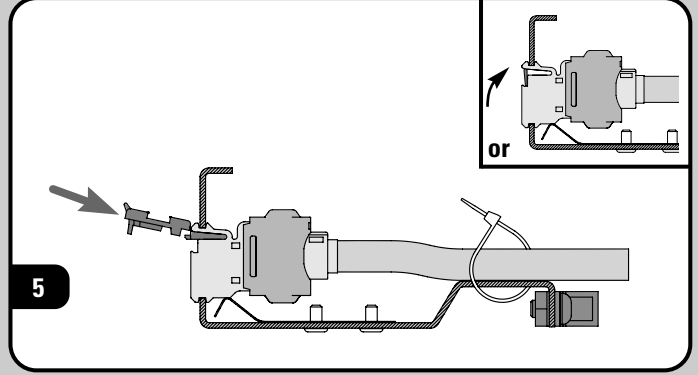

**To assist safe installations, comply with the following:**

- A. Use caution when installing or modifying telecommunications circuits.
- B. Never touch uninsulated wire terminals unless the circuit has been disconnected.
- C. Never install this device in a wet location.
- D. Never install wiring during a lightning storm.



**Global Headquarters**  
Watertown, Connecticut USA  
Tel: (1) 866-548-5814

For a complete listing of our global offices visit our web site

