

## BREAKOUT INSTRUCTIONS FOR ROUTING 6, 12, AND 24 FIBERS INTO COLOR CODED TUBES

### GENERAL

These instructions detail the installation of a Unitube/Central tube breakout kit. A kit breaks out 250µM fibers from a fiber cable into individual 900µM buffer tubes.

### SPLITTER KIT CONTENTS

Each breakout kit contains the following (see figure 1):

Cover  
Base  
Terminal assembly  
Shrink tube

### TOOLS AND MATERIALS (NOT INCLUDED)

- Electrical tape or masking tape
- Lint free wipes
- Indelible marker
- Buffer tube stripper
- Gel cleaner
- Heat gun

### DETERMINING STRIP LENGTH

Measure backwards, from the end of the cable to the point at which it will attach to the patch panel, and add 132 cm to the length.

Mark this length with a piece of tape. This is the jacket strip point for the cable being terminated.

### CABLE END PREPARATION

Follow the cable manufacturer's recommended sheath stripping procedures.

Strip the cable sheath back to the tape mark.

Clean any dirt and/or gel surrounding the loose tube.

### BUFFER TUBE PREPARATION

Slide the shrink tube over the tube and slide back to the cable jacket.

Measure back 92cm from the end of the tube and place a mark.

Score and remove 15 to 25cm of the tube at a time until you have removed all of the tube back to the mark. Be careful not to break any fibers.

Wipe all gel from the exposed fibers using a gel cleaner or isopropyl alcohol. Clean the outside of the remaining tube. Any gel or dirt may prevent the adhesive-lined shrink tubing from securing the tube to the breakout kit base.

Place the buffer tube in the buffer tube cavity of the breakout kit base. Route the bare fiber through the open front of the breakout kit base (see figure 2).

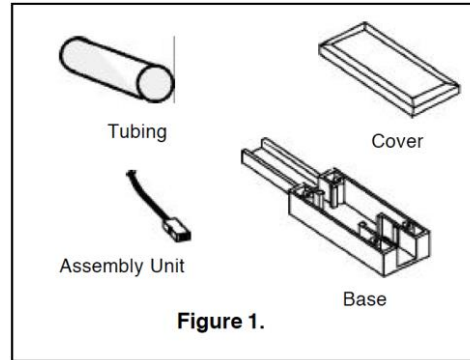

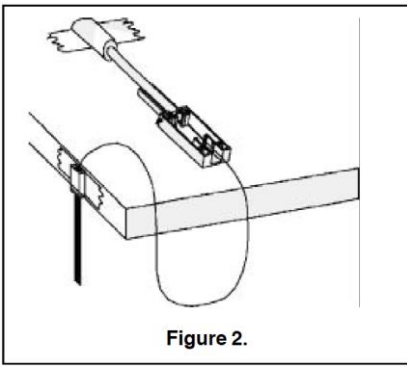

Figure 2.

Slide the shrink tubing over the tube and rear body of the breakout kit base.

With a heat gun, shrink the tubing. Be careful not to melt the breakout kit base.

### FIBER THREADING PROCEDURE

Untangle the fibers and make sure they are completely free of gel filling compound.

Talc (not provided) the fibers to facilitate the threading operation. Cup the talc in the palm of your hand and apply along the whole length of the fibers.

Select the blue fiber and thread 15cm into the blue tube of the terminal assembly (see figure 2).

Repeat this procedure for the remaining fibers making sure the color-coded fibers match the color-coded tubing.

When all the fibers have been threaded, push the fibers as a group until the fibers start to protrude from the ends of the buffer.

Gently pull the fibers from the ends of the buffer tubing. Do not pull the fibers taught. Leave sufficient slack so the fibers are not stressed.

Untape the terminal assembly and slide the assembly towards the breakout kit base while pulling the fibers from the end of the tubing. If the fibers twist, rotate the terminal assembly in the opposite direction of the twist (see figure 3).

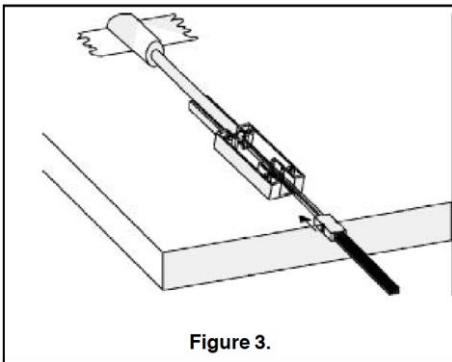

Figure 3.

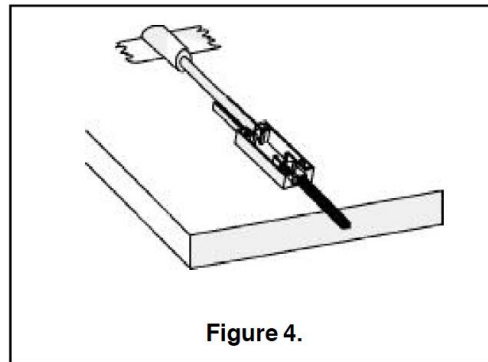

Figure 4.

Place the terminal assembly into its cavity in the bottom of the breakout kit base (see figure 4).

Note: For fiber counts above 12 fibers, two terminal assemblies are supplied. Above 12 fibers, the bare fibers will be sub-grouped and distinguished with the bare fiber color code repeated. Always place the the terminal assembly for the first sub-group in the bottom position of the breakout kit base.

Align the top cover and snap into place. Remove the tape securing the breakout kit base. The fibers are now ready for connector installation.