

Lightverse Plus Instructions

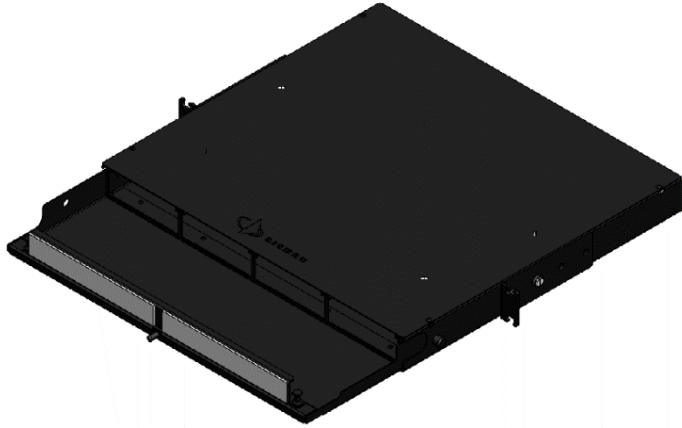

Hardware and Accessories



Tools



- A. Fiber managers (4)
- B. Mounting Bracket screws and washers (4)
- C. Roll of Velcro straps
- D. Velcro dots (2)
- E. Tie wraps
- F. Rack 12-24 screws and washers (4)
- G. Plastic grommets (4)
- H. Philips head screwdriver
- I. Diagonal cutter

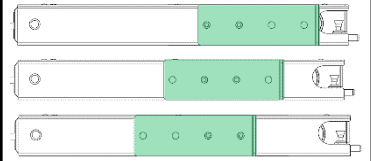

The mounting brackets can be mounted in three positions to provide different position placement in the mounting rails of a cabinet or rack.

1

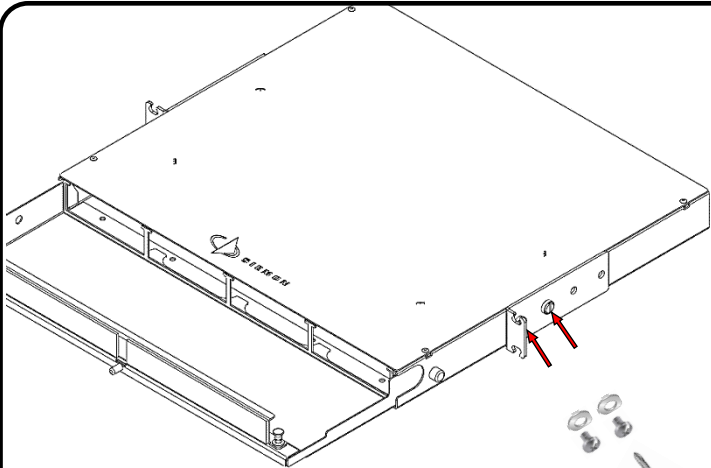

Brackets are held in place by two screws and washers each side.

2

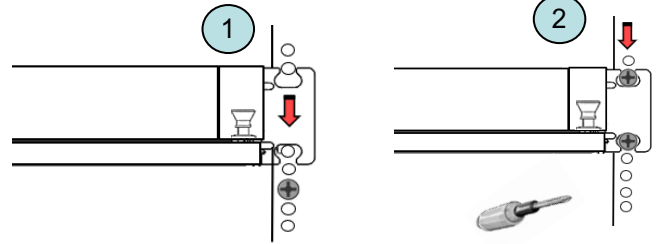

The open hole design of the rack mounting brackets can be utilized to allow for easier mounting. 1. Screw in mounting screws at desired height for bottom of the enclosure in the rack. The enclosure can then be lowered down onto the partially installed screws, tighten screws. 2. While the enclosure is held in place by the lower screws the top screws can then be used to secure it.

Mount enclosure to rack or cabinet rails using included #12-24 screws with washers.

3

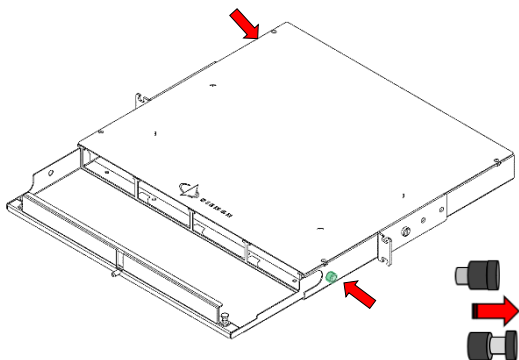

Release the spring latch located on the front right (forward tray access) and rear left (backward tray access) to allow motion either forward or backward. Tray can be completely removed from the front or the back.

4

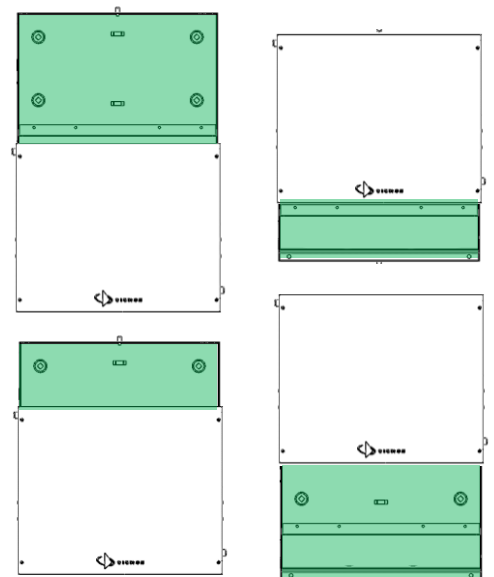

The enclosure tray has two spring latch lock positions rear and two spring latch lock positions forward.

5

Lightverse Plus Instructions

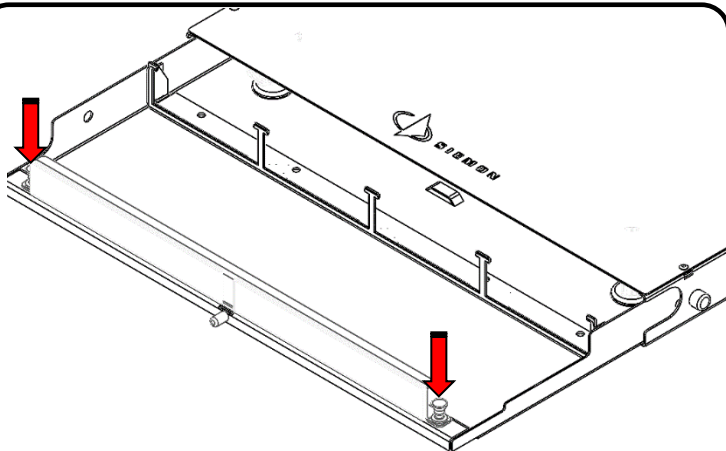

Label holder can be removed by pulling up on the securing plastic latch shown above. Reverse step to reattach.

6

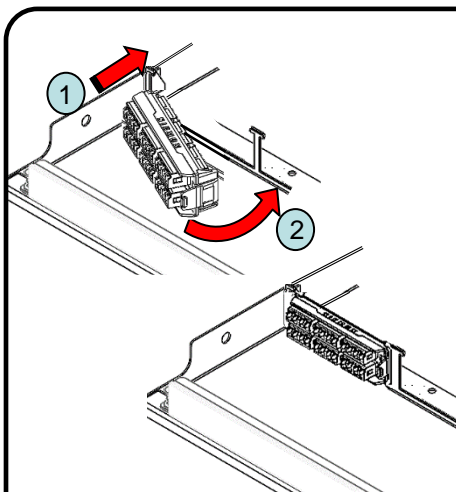

To insert the adapter plate, engage the left side of the plate into the panel first, ensure that the SIEMON logo is facing up as shown. Next rotate the plate to the right and snap into place.

7

Lightverse Adapter Plate



To remove the adapter plate, depress the latch on the right side of the plate and rotate toward the left. The plate can then be removed from the panel.

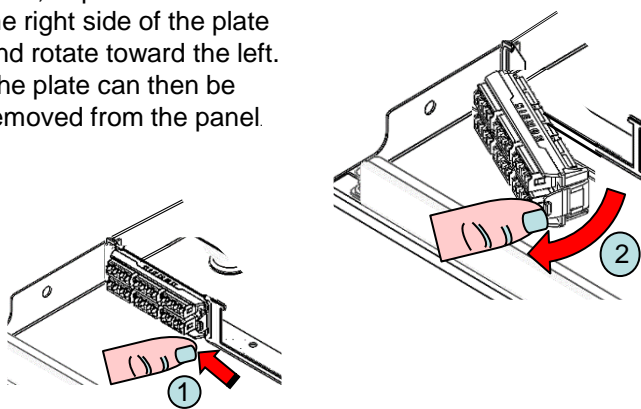

8

To insert the module or cassette from the front of the panel, push it forward while compressing the front release tabs until locked into position.

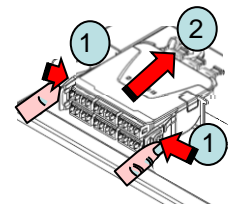

To remove, compress the front release tabs on each side of the module or cassette and pull forward.

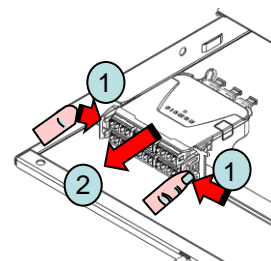

9

Lightverse Plug and Play and Splice Cassette



Ensure that only the front of the release tabs are depressed as cassette is inserted.

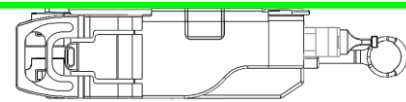
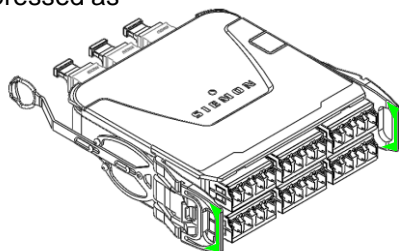

Ensure that the cassette is level as being inserted.

10



To insert the module or cassette from the back of the panel, push it forward until locked into position.

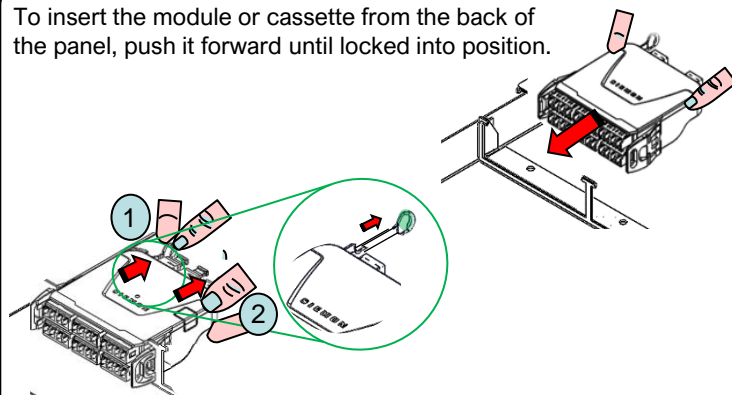

To remove the module or cassette from the rear of the panel, pull the release tether straight back to disengage from the panel and pull the module free.

11



Lightverse Plus Instructions

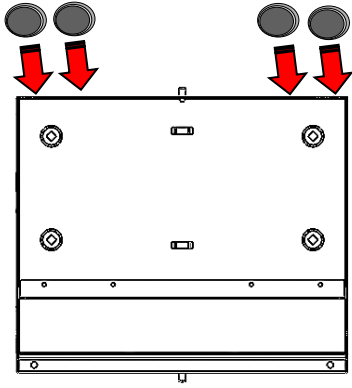

Feed through grommets allow for cable to pass into enclosure while protecting it from sharp edges. The feed through grommets can also be used as dust caps in unused openings.

12

Optional Compression fitting(s) can be used in place of the grommet. Position the fitting at least one meter from the cut end of cable. Tighten the clamp nut against the cable jacket. Loosen the hex nut and insert the externally threaded portion of the fitting into the selected cable access hole. Re-tighten the hex nut to secure the fitting to the tray.

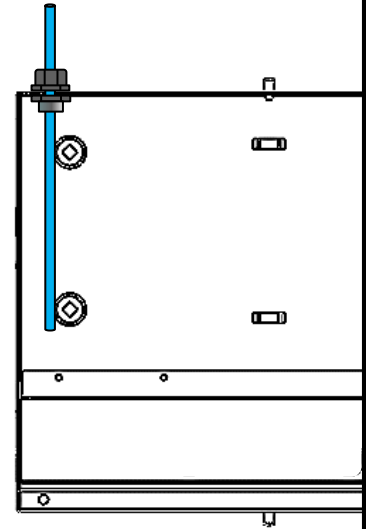

13

When used, splice tray(s) should be positioned in the center of the fiber storage platform as shown. Secure the tray(s) to the floor of the fiber storage tray using the Velcro strap and lance points as shown.

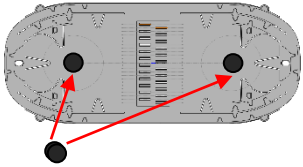
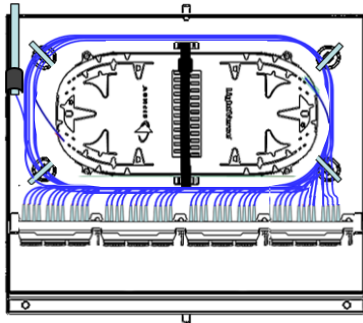

Note: If using only one splice tray Velcro dots included with the enclosure can be used to stabilize the tray in conjunction with the strap shown above. Dots should be placed as shown on the underside of the tray

15

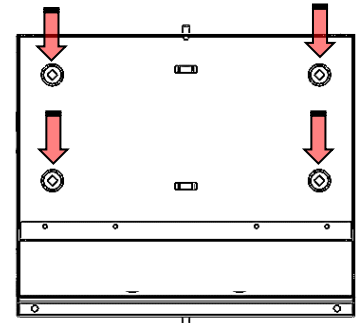
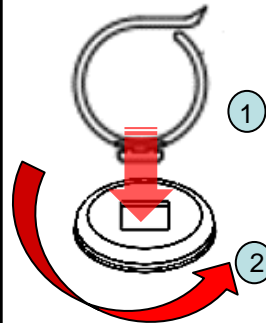

Fiber Managers can be installed on any of the 1/4 turn features shown above. Install fiber management clips in the rear of the enclosure by inserting into appropriate holes and turning 45 degrees to lock into place. (Manager opening should face the outer walls of the enclosure in rear.)

16

Fiber Management examples with adapter plates/modules/cassettes

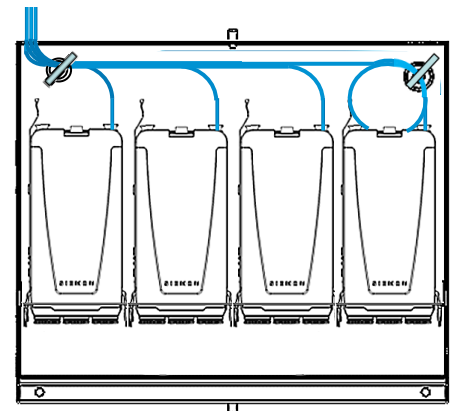
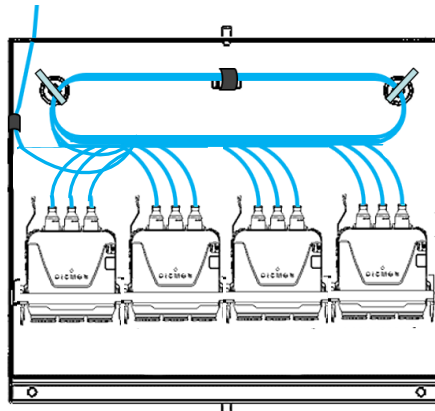
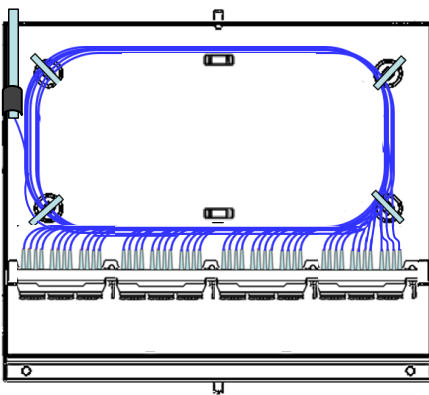

17

Lightverse Plus Instructions

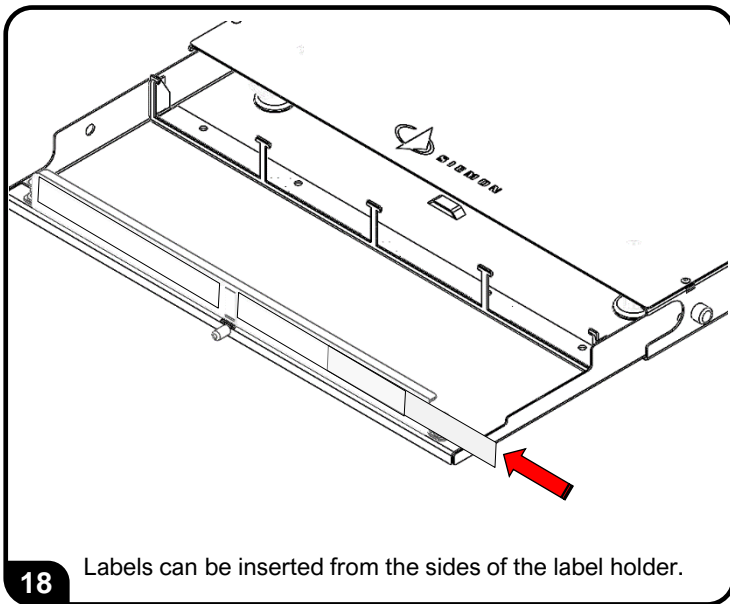

To assist safe installations, comply with the following:

- A. Use caution when installing or modifying telecommunications circuits.
- B. Never touch uninsulated wire terminals unless the circuit has been disconnected.
- C. Never install this device in a wet location.
- D. Never install wiring during a lightning storm.

Lors de l'installation, respectez les consignes de sécurité suivantes:

- A. Utiliser avec prudence lors de l'installation ou de la modification circuits de télécommunications.
- B. Ne jamais toucher les bornes de fil métallique non isolés sauf si le circuit a été débranché.
- C. Ne jamais installer cet appareil dans un endroit humide.
- D. Ne jamais installer pendant un orage.

To ensure you have the latest revision to this document, please visit: www.Siemon.com



Global Headquarters
Watertown, Connecticut USA
Tel: (1) 866-548-5814

For a complete listing of our global offices visit our web site