

LightStack® Ultra-High-Density Plug and Play System

PATENTED

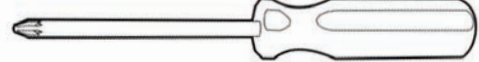

Tools

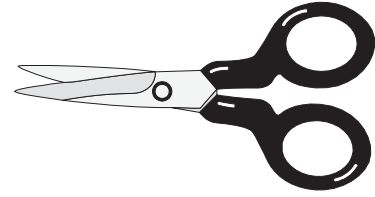
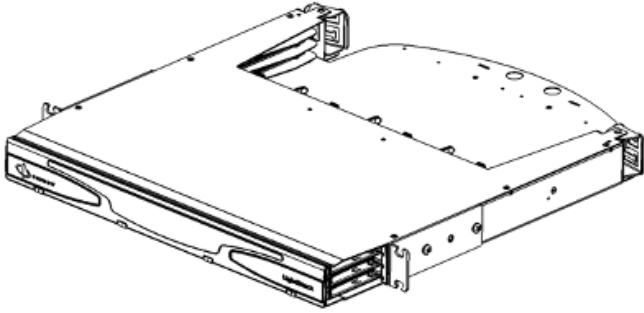
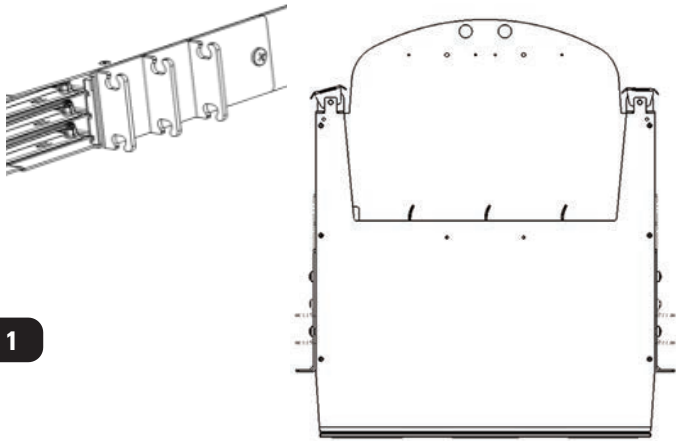

1

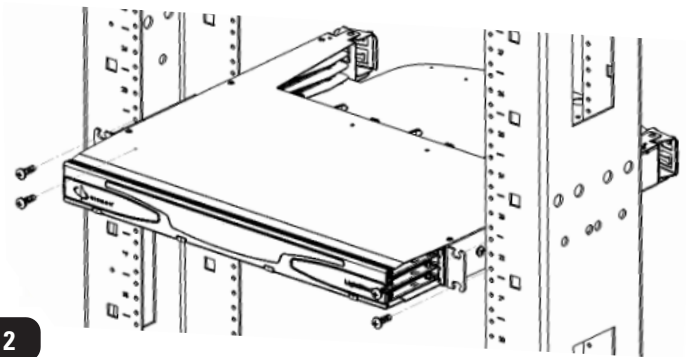

2

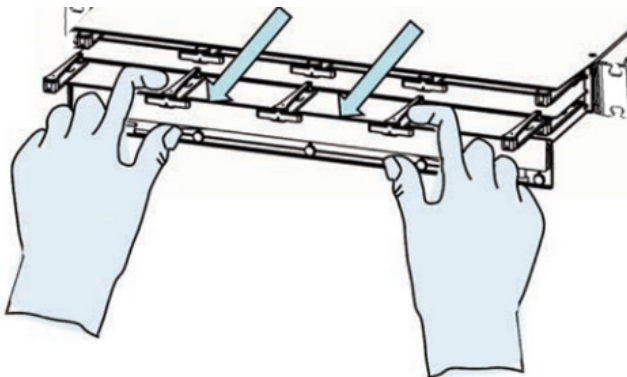

3

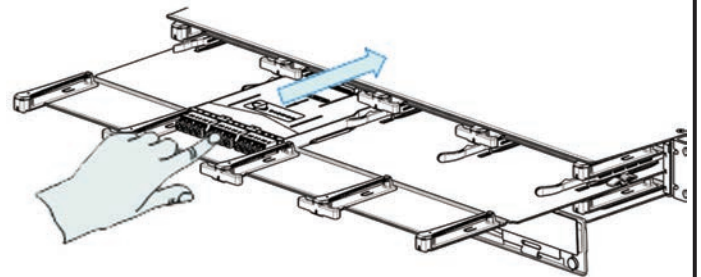

4

LightStack® Ultra-High-Density Plug and Play System

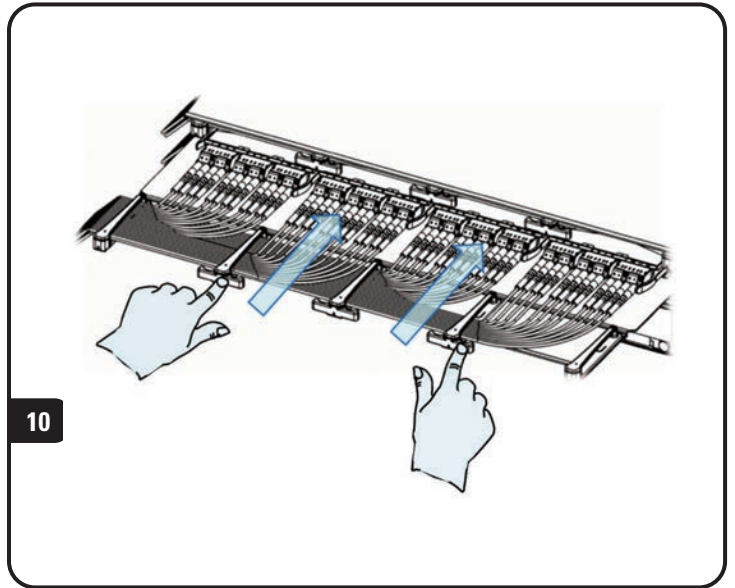
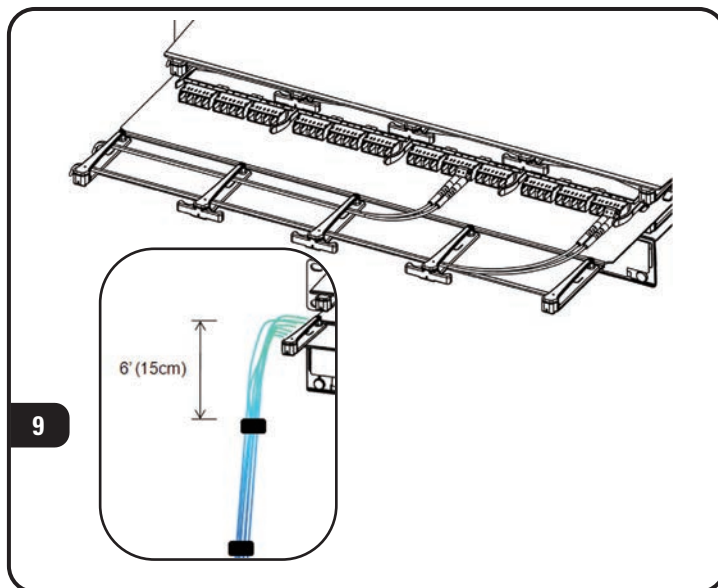
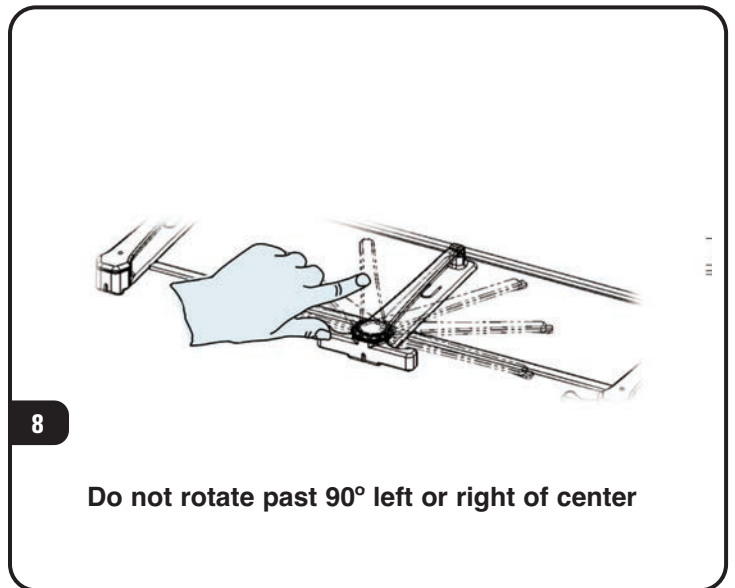
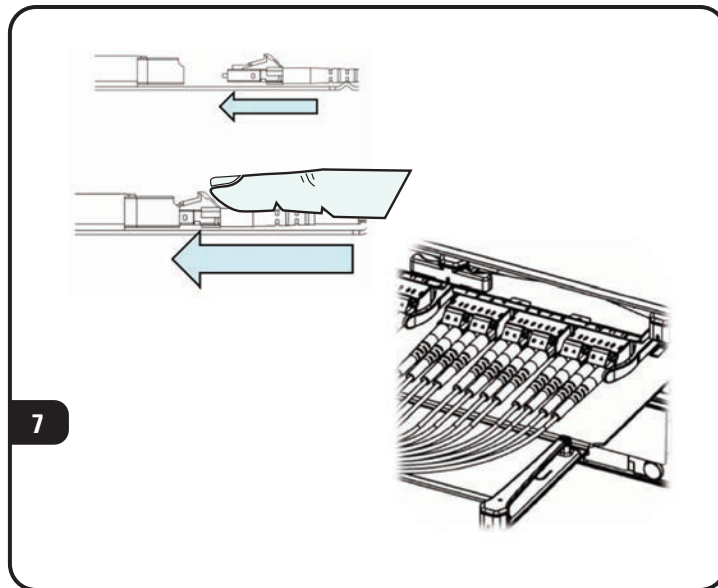
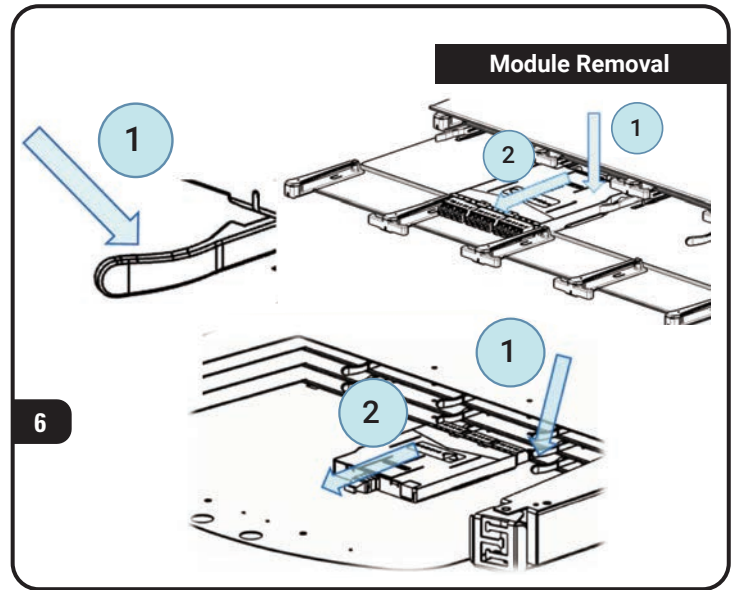
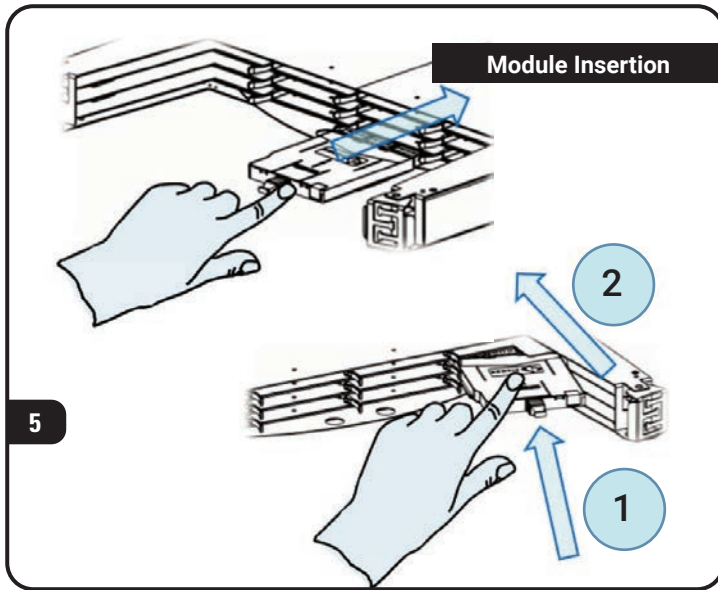

LightStack® Ultra-High-Density Plug and Play System

1. Leg farthest from Tie down bracket
21.25" (54cm)

2. Leg 2nd farthest from Tie down bracket
18" (46cm)

3. Leg 3rd farthest from Tie down bracket
14.5" (37cm)

4. Leg 4th farthest from Tie down bracket
13.75" (35cm)

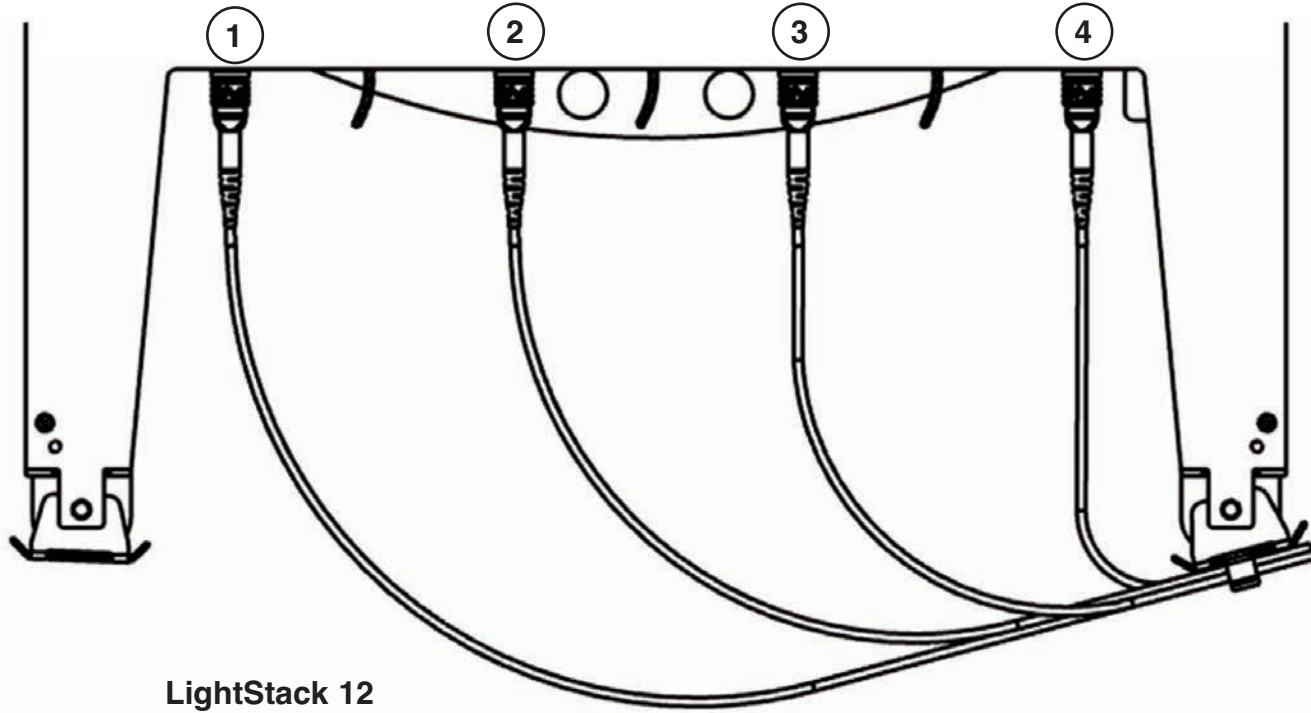

LightStack 12

Leg length should be measured from end of connector down cable. Cable should be measured straight

11A



LightStack® Ultra-High-Density Plug and Play System

- | | | | | | |
|---|---|--|---|---|---|
| 1. Leg farthest from Tie down bracket
21.5" (54.6cm) | 2. Leg 2nd farthest from Tie down bracket
18" (45.7cm) | 3. Leg 3rd farthest from Tie down bracket
15.5" (39.37cm) | 4. Leg 4th farthest from Tie down bracket
14.5" (36.8cm) | 5. Leg 5th farthest from Tie down bracket
13.5" (34.3cm) | 6. Leg 6th farthest from Tie down bracket
13" (33cm) |
|---|---|--|---|---|---|

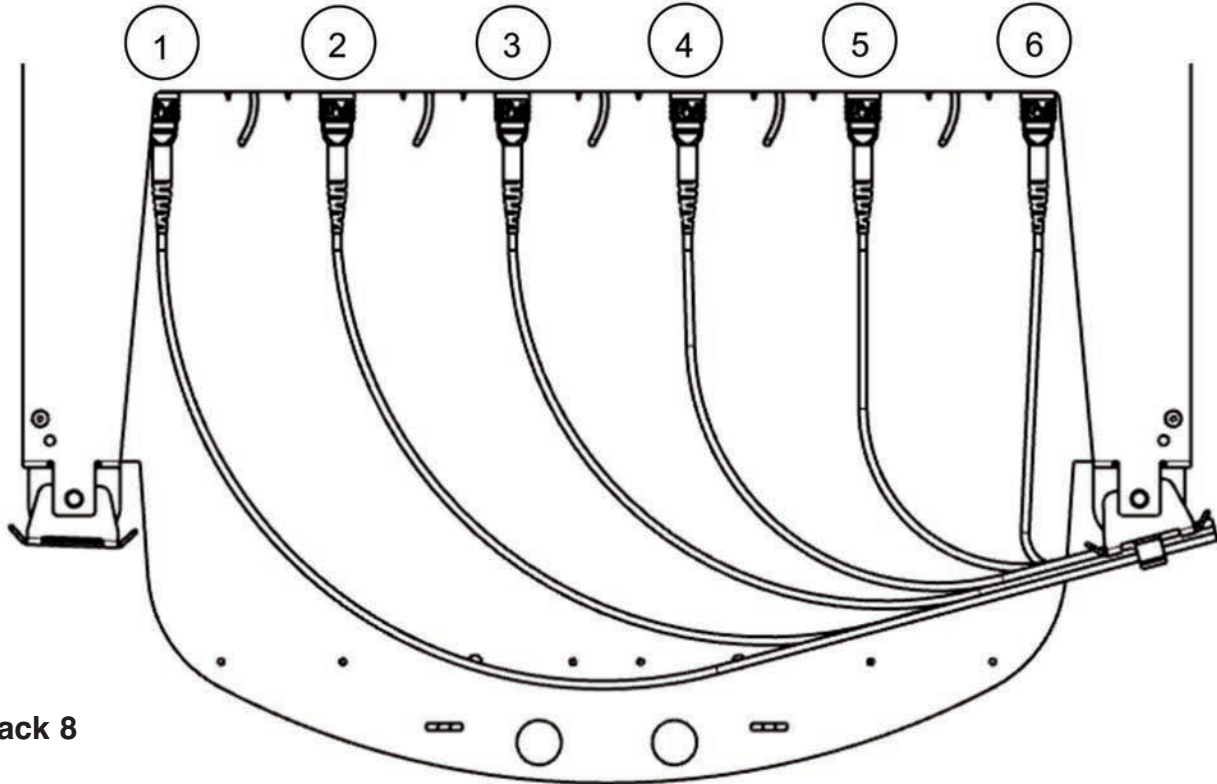

LightStack 8

Leg length should be measured from end of connector down cable. Cable should be measured straight

11B



12

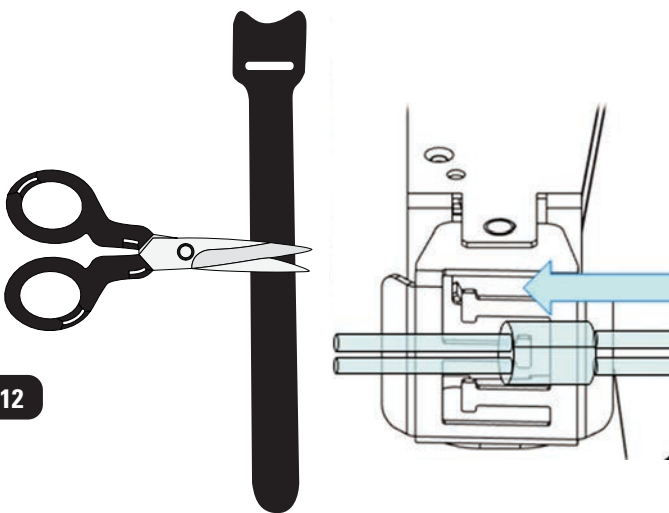

13

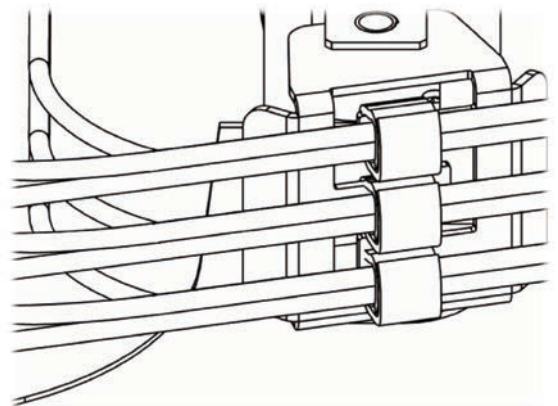

LightStack® Ultra-High-Density Plug and Play System

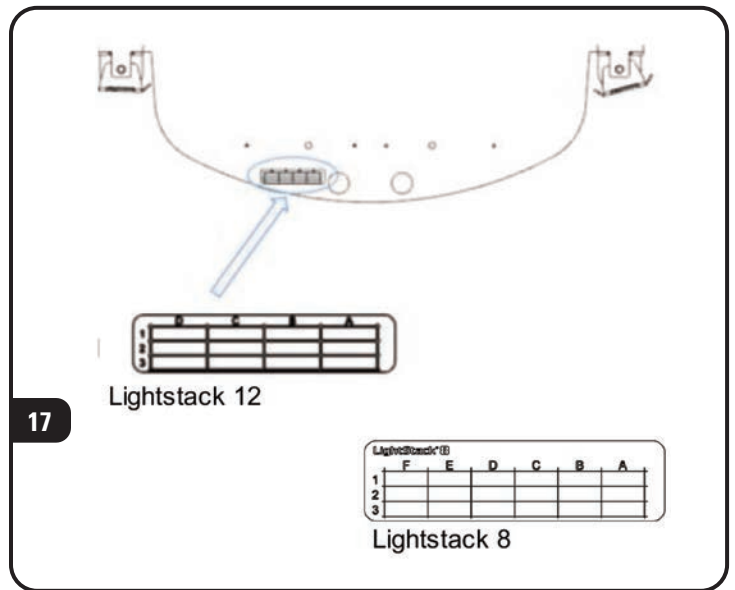
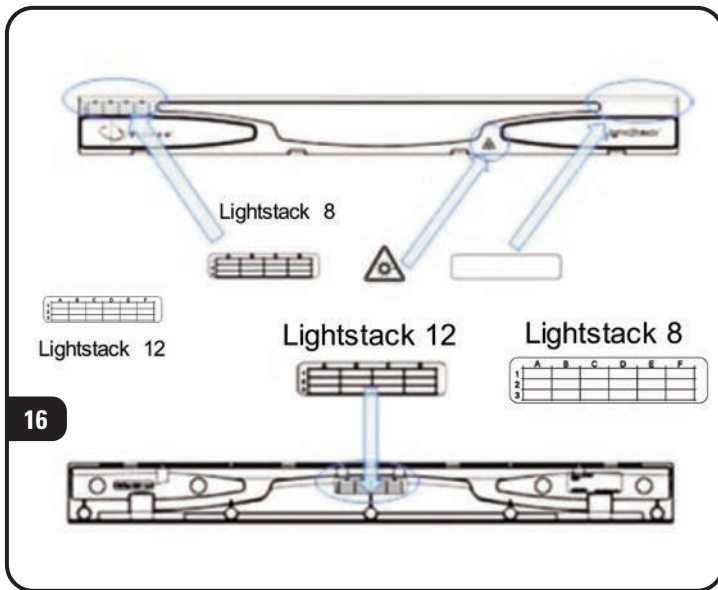
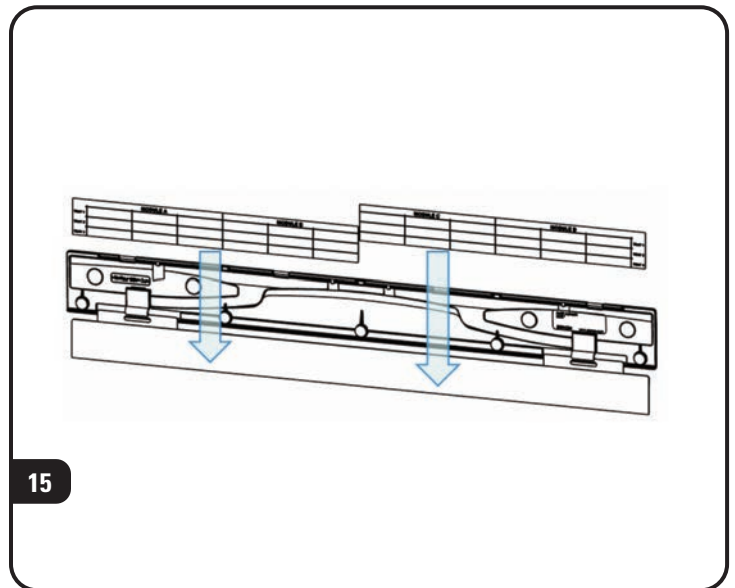
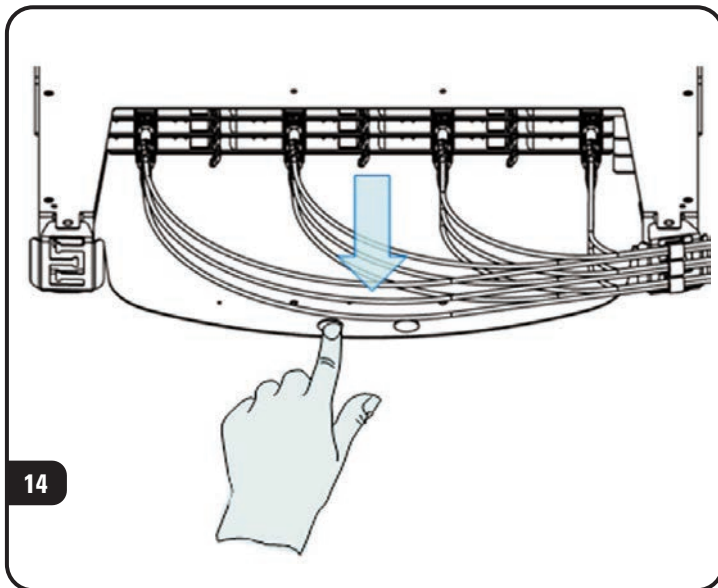

To assist safe installations, comply with the following:

- A. Use caution when installing or modifying telecommunications circuits.
- B. Never touch uninsulated wire terminals unless the circuit has been disconnected.
- C. Never install this device in a wet location.
- D. Never install wiring during a lightning storm.

Global Headquarters

Watertown, Connecticut USA
Tel: (1) 866-548-5814

For a complete listing of our global offices visit our web site

**The Siemon Company
Australia**

Sydney, Australia
Tel: (61) 2 89977 7500

**The Siemon Company
Canada**

Markham, Ontario
Tel: (1) 905 940 9223

**The Siemon Company
China**

Beijing, P.R. China
Tel: (86) 10 6559 8860

**The Siemon Company Ltd.
Europe & Middle East**

Woking, England
Tel: (44) (0) 1483 480040

**The Siemon Company
Latin America**

Coral Gables, Florida USA
Tel: (1) 305 446 9150

**Latin American Sales
Manufacturer's Representatives**

Castroville, Texas USA
Tel: (1) 830 538 6375

**The Siemon Company
Southeast Asia**

Singapore
Tel: (65) 285 7579

**The Siemon Company
USA**

Watertown, Connecticut
Tel: (1) 866 548 5814

