

PICO PROTECTOR[®] PG-50 & PK-50 Series

Installation Instructions



LISTED E120203

"Secondary Protection for Communications Circuits"

Introduction

The Siemon Company's Pico Protector® Kits protect voice and data equipment from sneak current and voltage surge conditions that may occur beyond primary protection devices. Such conditions may cause fire, electrical shock, and damage to customer premises equipment (CPE). This secondary line protection is installed behind the network interface device (NID) and used in conjunction with primary protection devices (when required).

Both the PG and PK series kits follow the same installation instruction procedure. For proper protection, a ground cable must be connected to the kit's terminal-plate assembly.

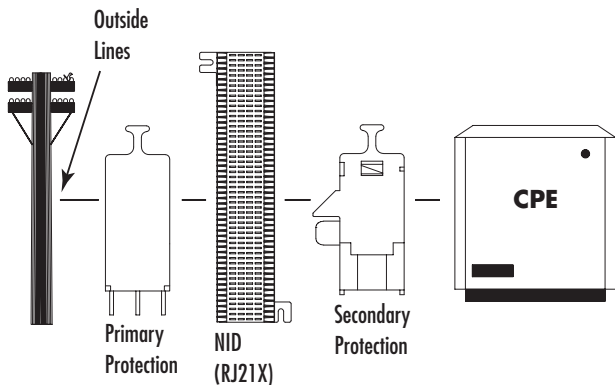

Figure A

Safety Considerations

For UL 497A compliance the PICO Protector® is installed in a UL listed type 1 enclosure with UL listed Siemon Company S66M series connecting blocks. The installation is to be in accordance with National Electric Code requirements and local authorities. Connecting blocks may be purchased separately or in kit form with grounding hardware.

Pico Protector ground kits and protector modules are purchased separately.

Protectors must be installed and maintained by trained service personnel only.

WARNING:

This product may only be installed on the protected side of the primary building entrance protector (when present). These instruction procedures must be followed explicitly to avoid safety hazards to equipment, plant and personnel.

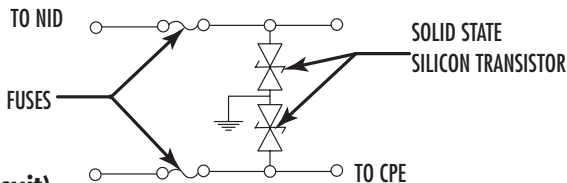

**Figure B
(Pico Circuit)**

Ground kits for 50-pair protection

P/N: PG-50 & PK-50 series

General:

The PG-50 kit is used on 66M blocks loaded with four columns of electrically isolated quick clips. It may be added to blocks that are already installed or used on new installations. PK-50 series kits consist of the PG-50 ground kit, a M1-100 connecting block and a S89D bracket. Consult factory to determine block best suited to meet specific applications.

PG-50 Kit includes:

- One terminal-support assembly plate with two snap-on mounting ears
- Two 4-inch female-ended quick-connect jumpers
- Two 8-inch female-ended quick-connect jumpers
- Two bus bar assemblies

1. Mount block:

For proper installation clips in rows A&D (outside columns) must be wired to the network interface or primary protection. Rows B&C (inside columns) must be wired to premises equipment. The PICO modules provide the bridging between two adjacent columns. If bridging clips are in place, they must be selectively removed prior to module installation.

2. Attach bus bars to block:

Align each bus bar with a fanning strip. Bus bar contacts should face the center of the block. Slide the bus bars onto each fanning strip using the outside mounting position. See Figure C.

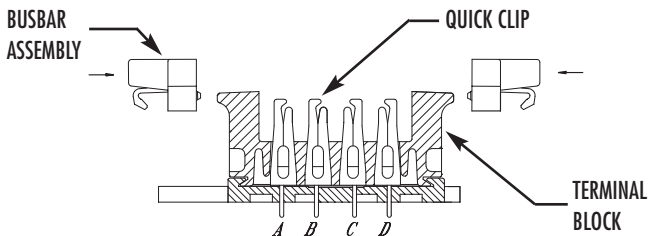

Figure C

3. Mount terminal support assembly:

Snap terminal-support assembly onto the central portion of the block's fanning strip. See Figure D.

4. Attach ground wire:

Connect #6 ground wire (not included) to terminal-support assembly by sliding the ground wire into the box lug on the plate and tightening the screw (slotted screw driver required). See Figure D.

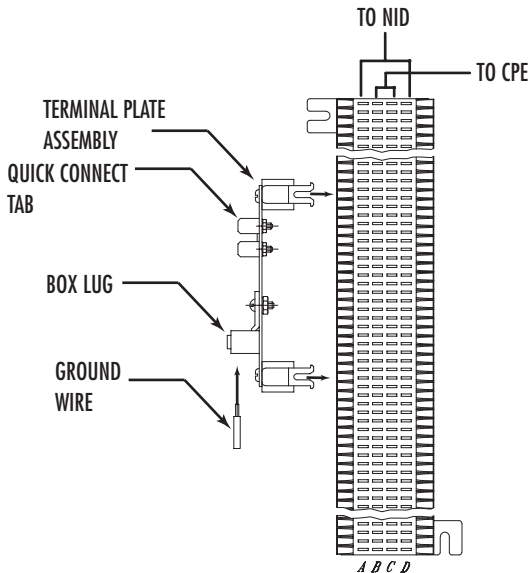

Figure D

5. Attach grounding jumper wires:

Connect one end of each 4-inch jumper wire to a male quick-connect tab on the terminal-support assembly and the other end of each jumper wire to a jumper receptacle on the left bus bar assembly. Connect one end of each 8-inch jumper wire to a male quick-connect tab on the terminal-support assembly. Lace the jumpers through the bracket and behind the block to the other side of the bracket. Connect the other end of each wire to a jumper receptacle tab on the opposite bus bar assembly. See Figure E.

For each connectorized blocks, the jumpers may be laced behind the 25-pair connectors. **The bus bar assemblies are not properly grounded unless each is connected to the terminal support assembly with two jumper wires.**

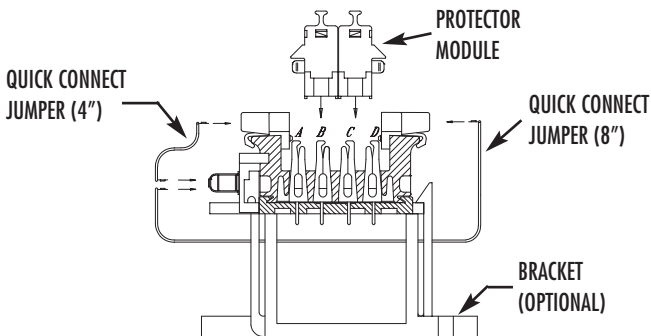

Figure E

6. Mount modules:

Push each module into the clips bridging columns A&B or C&D, taking care that the ground tab on each module mates with one of the 50 bus bar contacts. See Figure E.

7. Circuit designations:

Write circuit designations on grounding-tab shroud of module. Slide optional red designation caps onto the handle to designate priority circuits. See Figure F.

Pico Protector® Trouble Guide

Follow steps 1 - 3 if signal lost at the workstation outlet:

1. Disconnect all premises equipment and test (using TP-4P, see Figure G) for tone on CPE side of the Pico Module (side opposite ground tab).
 - a. If tone registers, the trouble is between the outlet and the secondary protector block. Trace the line back to the workstation outlet to identify and repair.
 - b. If tone does not register, proceed to step 2.

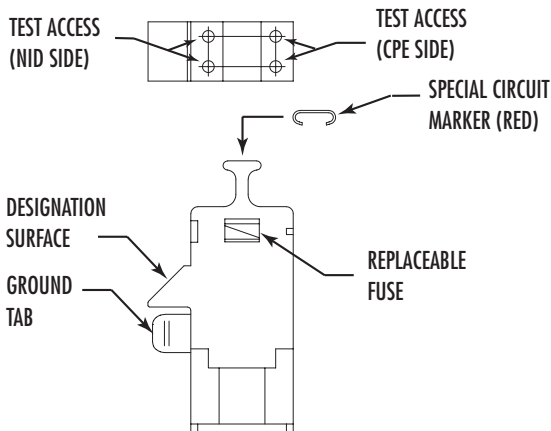

Figure F

2. Test for tone on the NID side of the Pico Module (same side as ground tab).
 - a. Tone registering on NID side but not on CPE side indicates a blown fuse(s). Remove module and replace spent fuse(s) using a 1/16" diameter probe (TP-4P). Fully seated fuses are recessed in housing approximately 0.10 inch. Re-install the module and test.
 - b. No tone on both the NID and CPE sides of the installation Pico Module indicates either a case of trouble on the incoming line or a transistor malfunction in the module (provided that all premises equipment is disconnected). See caution and proceed to step 3.
3. Remove the module and test the quick clips wired to the NID.
 - a. If tone registers, the transistor in the module has failed short to ground due to a catastrophic voltage surge. Discard the old module and replace it with a new one of the same part number. Retest.
 - b. If no tone registers, the trouble is with the incoming line. Reinsert the module and test the circuit at the building entrance point (NID) or primary protection to isolate the trouble.

continued page 10

CAUTION:

If no tone exists on both the CPE and NID sides of the module and one or more of the fuses are blown, a sustained voltage surge condition may exist that is below the breakdown voltage of the primary protector. For this case, care must be taken by service personnel to avoid electrical shock until the line is checked and treated for the presence of an extemporaneous voltage source.

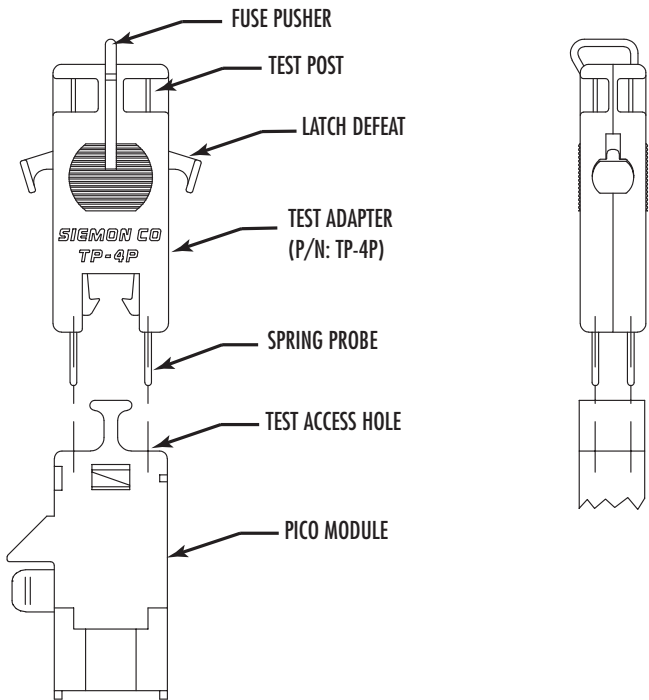

Figure G

Accessory Information

P/N	Description	Std. Pck.
CP-675-C	Red designation caps	100/bag
TP-4P	4-point test probe	10/box
SF-035	Replacement fuses	20/bag

Modules:

P/N	Clamping Level \pm 10%	Std. Pck.
PM-007	7V	100/ctn.*
PM-027	27V	100/ctn.*
PM-068	68V	100/ctn.*
PM-140	140V	100/ctn.*
PM-180	180V	100/ctn.*
PM-230	230V	100/ctn.*

*packed 25 per box

Global Headquarters

Watertown, Connecticut USA

Tel: (1) 866-548-5814

For a complete listing of our global offices visit our web site

