

# Instructions for The Siemon Company 50- and 100-pair mounting legs

This sheet is intended for use with The Siemon Company 50- and 100-pair, 110 wiring blocks with mounting legs. The S110L mounting legs allow the blocks to be mounted on any flat surface. Instructions given below should be followed for proper installation.

The S110L mounting legs are supplied in a set of 2. It is recommended to attach the legs to the wiring block before mounting in order to correctly position the legs on the mounting surface. To attach the mounting legs to the wiring block, position the legs behind the wiring block as shown. Using thumb and index finger to depress the latches inward, guide the latches into the outer channels of the wiring block. Alignment tabs on the legs also fit into channels on the wiring block. Push the components together until the latches “snap” into place.

Mount the S110 100- and/or 50-pair blocks with legs on a flat mounting surface. Using a minimum of 2 mounting screws per leg (in the outer-most positions) will ensure secure positioning of the blocks for termination. A total of 4 screws should be used for the S110AW1-100 or S110AW1-50 wiring blocks with legs, and at minimum, 1 screw per mounting leg (8 screws total) should be used in part number S110AW1-300 for proper mounting security.

For additional security, the assembly can be fastened together using the self-tapping, Phillips-head screws included. Screws can be inserted (2 screws per leg for the 100-pair block and 1 screw per leg for the 50-pair block) from the front of the wiring block into the screw holes indicated below.

**FIGURE 4 — ASSEMBLING  
THE S110L MOUNTING  
LEGS TO THE S110  
WIRING BLOCK**

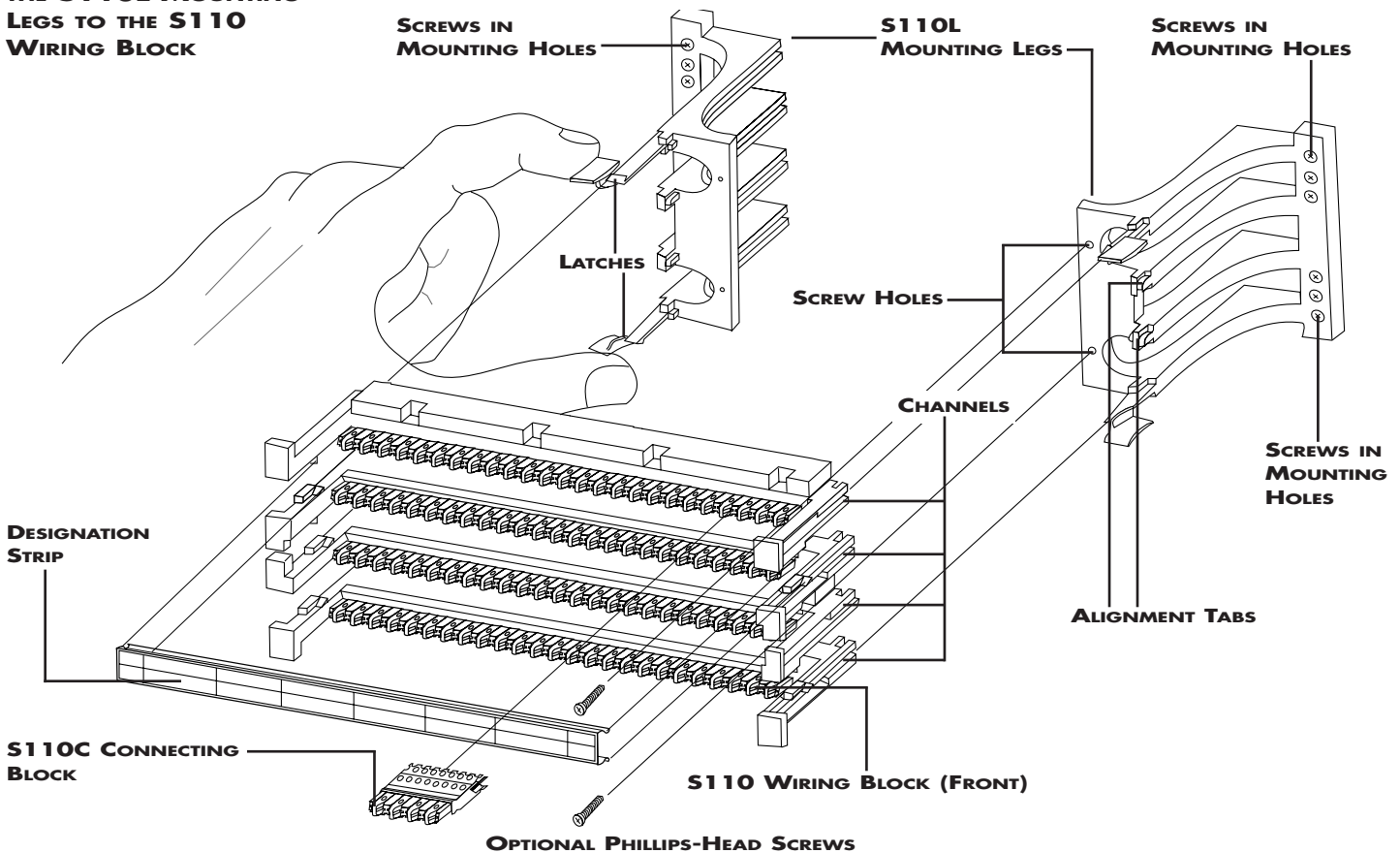

**TO ASSIST SAFE INSTALLATION,  
COMPLY WITH THE FOLLOWING:**

- A. Use caution when installing or modifying telecommunications circuits.
- B. Never touch uninsulated wire or terminals unless the circuit has been disconnected.
- C. Never install this device in a wet location.
- D. Never install cabling during a lightning storm.

These instructions apply to both the 50- and 100-pair wiring blocks and mounting legs. Consult factory for information regarding rack mount applications.

COMMUNICATION CIRCUIT  
ACCESSORY LISTED 57S5  
  
CSA C22.2 APPROVED

**Global Headquarters**  
Watertown, Connecticut USA  
Tel: (1) 866-548-5814

For a complete listing of our global offices visit our web site

 **SIEMON™**  
[www.siemon.com](http://www.siemon.com)

# Instructions for wiring 25-, 50-, 75-, 100-, and 300-pair Siemon Company S110® Wiring Blocks

This information is intended to illustrate proper wiring procedures for the 25-, 50-, 75-, 100- and 300-pair, S110 wiring blocks. Step-by-step instructions given below should be followed for proper wiring installation.

## STEP 1 – Configuring horizontal or backbone cables to the wiring block

Remove the outer jacket of the horizontal or backbone cable up to 10 in. (254mm) from the cable end. This allows individual pairs to be seated in the termination strip as shown in Figure 1. Cut-outs have been provided for optional cable access through the back of the wiring block.

The tip wire of pair-1, T1 (white), should be laced into the first or left-most slot. The ring wire of pair-1, R1 (blue), should be laced into the next slot to the right. Care should be taken to maintain twists as close as possible, 0.5 in. (13mm) or less, to the termination strip. Subsequent pairs should follow this same pattern always keeping the tip (white) wire to the left of the ring wire. No more than one wire should be seated into each slot. For convenience, every fifth pair has been designated by a notch and black marking.

After each pair has been laced into the termination strip, excess wire should be trimmed with the cutting edge of an impact tool.

## STEP 2 – Seating the S110C connecting blocks

Once each pair has been laced and trimmed, the S110C connecting blocks are ready to be seated to the termination strip. Orientate the connecting block as shown in Figure 2 with the blue marking on the left (dark strip down). Seat the connecting block using Siemon P/N S788J1 5-pair impact tool or equivalent. Snap designation strips over the triangular hooks in the wiring block (Figure 4 on reverse). If cables are routed according to Figure 1, wiring can be covered with designation strips for a neater appearance.

## STEP 3 – Terminating cross-connect wires to the connecting blocks

The S110C connecting block is a double-ended, insulation displacement connector. It should be noted that only 22 through 26 AWG (0.64-0.40mm) insulated wire should be used with this connector.

Once the connecting blocks have been seated and designation strips snapped into place, cross-connection wires can be terminated to the top of the S110C connecting blocks. Arrange wires as shown in Figure 3 and terminate using Siemon Company P/N S814 impact tool or equivalent. The Siemon S788J1 5-pair impact tool may be used for terminating wires to the top or all 110C-type connecting blocks. Make sure all conductors have been completely seated at the bottom of the wire slots and trim any excess wire using the cutting edge of either impact tool.

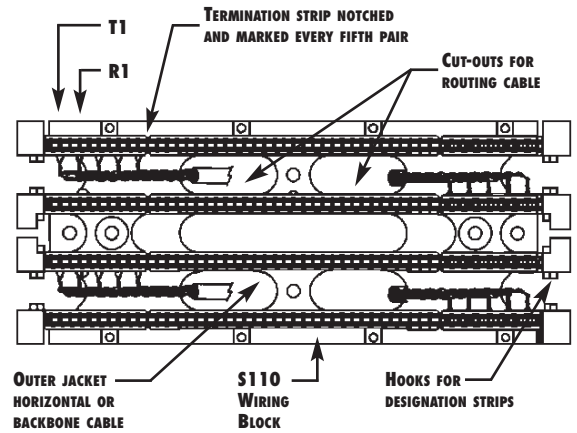

**FIGURE 1**  
CONFIGURE HORIZONTAL OR BACKBONE CABLE TO THE S110 WIRING BLOCK  
(FOR SIMPLICITY, ONLY 5 TWISTED PAIRS ARE SHOWN FOR EACH CABLE)

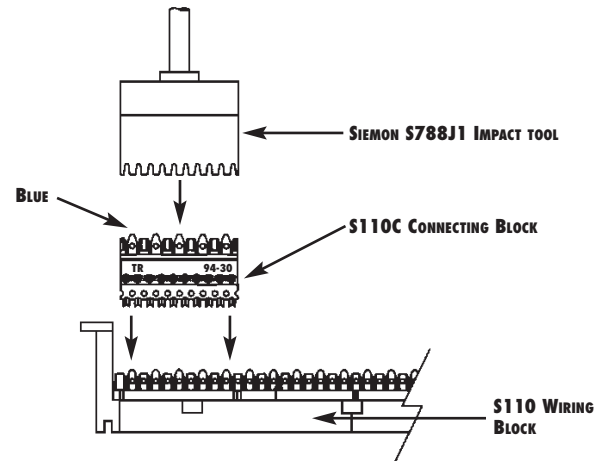

**FIGURE 2**  
SEATING THE S110C CONNECTING BLOCK

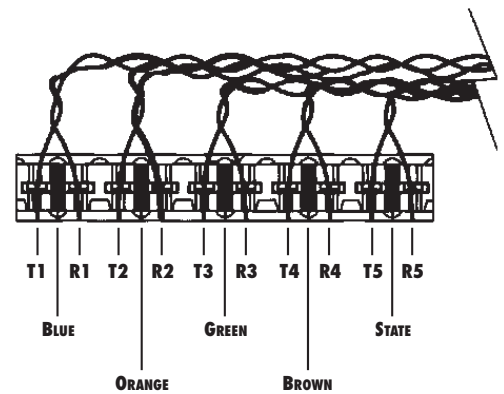

**FIGURE 3**  
TOP VIEW OF A 5-PAIR S110C CONNECTING BLOCK