

# Plug and Play Solutions Guide

QUALITY. PERFORMANCE. INNOVATION.

[www.siemon.com/plug-and-play](http://www.siemon.com/plug-and-play)

Connecting the World to a Higher Standard

# Contents

The Siemon Difference .....	3
High-Performance Cabling, High-Speed Deployment .....	4
Industry Leading Performance, By Design .....	5
Enclosures and Panels   LightVerse® .....	6
Enclosures and Panels   LightStack™ UHD .....	7
Modules   LightVerse® .....	8
Adapter Plates   LightVerse® .....	9
Trunks   Base-8 MTP-to-MTP .....	11
Trunks   Base-12 MTP-to-MTP .....	12
Trunks   Base-8 MTP-to-LC .....	13
Trunks   Base-12 MTP-to-LC .....	14
Fiber Jumpers   LC BladePatch® .....	15
Fiber Jumpers   Base-8 MTP-to-LC .....	16
Fiber Jumpers   Base-12 MTP-to-LC .....	17
Fiber Jumpers   Base-8 MTP® Pro-to-MTP Pro .....	18
Fiber Jumpers   Base-12 MTP® Pro-to-MTP Pro .....	19
Conversion Cords   Base-12-to-Base-8 .....	20
Conversion Cords   Base-12-to-Base-24 .....	21
How Can you Master Polarity? .....	22

# The Siemon Difference

## QUALITY. PERFORMANCE. INNOVATION.

High quality and standards exceeding performance are both attributes that customers have come to expect and trust from Siemon solutions, and our state-of-the-art fiber optic plug and play portfolio is no different.

Our experts have developed a range of solutions capable of supporting your needs today and for the future, while our experienced technical support teams are always on hand to support you with in-depth designs, migration planning as well as information on the latest trends, technologies and considerations you need to be aware of to fully harness the potential of your network infrastructure.

Whether it's day 1, or 3,001, the combination of our excellent solutions and support services ensure that you have everything you need to achieve your goals.

## High-Performance Cabling, High-Speed Deployment

Fiber optic cabling has become the dominant connectivity medium in today's data center environments and continues to grow in importance for LAN spaces. This adoption has been driven by the emergence of new technologies, and an increasing range of applications, which are all demanding higher bandwidth and low-latency transmission.

As networking environments become more complex to support these increasing demands, fiber cabling densities also continue to rise. As a result, you need innovative, robust solutions which will allow you to easily design, deliver and manage your critical fiber infrastructure for now and the future. **Siemon's innovative range of fiber optic plug and play solutions are the ideal fit.**

At Siemon we pride ourselves on our engineering heritage, innovation, and our data center pedigree. We've taken this passion and focused it into a truly world-class portfolio of advanced fiber optic plug and play solutions, which have been designed from the ground up to support your ever-changing requirements for now and the future. All backed-up by Siemon's industry-leading quality, performance, and reliability they combine to help you reduce risk, maximize uptime and successfully deliver new applications and services at speed.

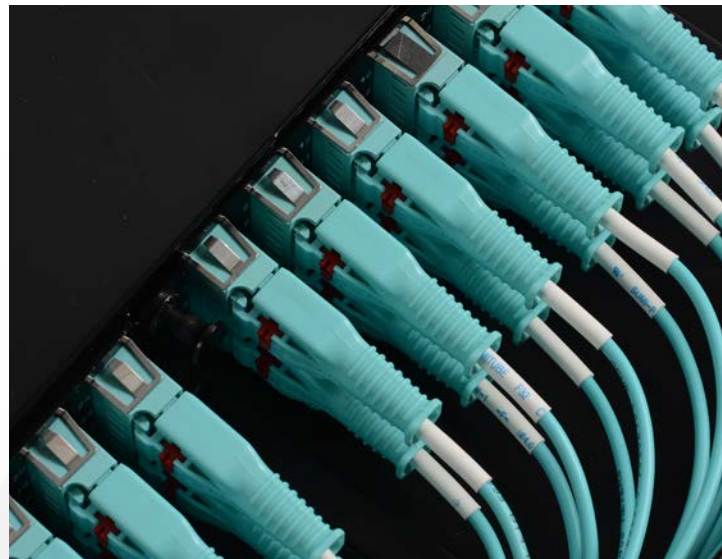
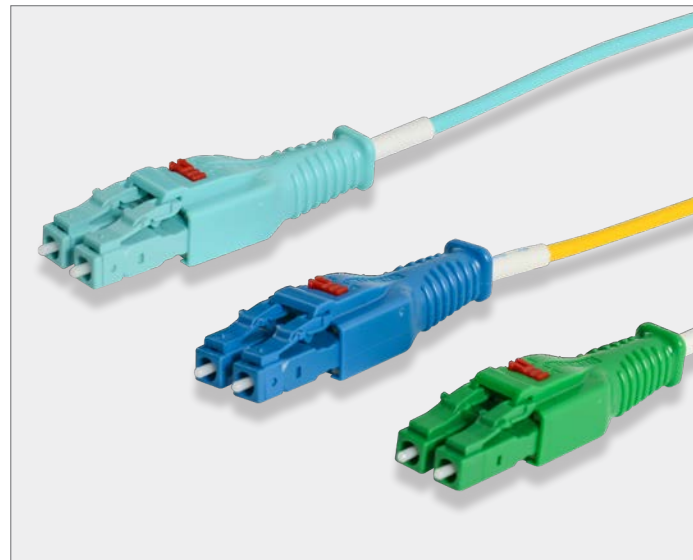

## Industry Leading Performance, By Design

# WITH SIEMON FIBER, YOU DON'T HAVE TO COMPROMISE.

At Siemon, we don't believe that our customers should settle when it comes to their optical performance. That's why we've developed our plug and play solutions in line with the most stringent industry standards, which allows our customers to have peace of mind that they will have the flexibility they need over a range of distances and configurations, all while remaining within their loss budget.

### Our Best Is Better

We like to keep things simple, so we only provide two performance options.

1. Our **Standard Loss** components are in line with many other industry leaders' "low loss" offerings, which means that our standard is the same as their "best".
2. Our **Ultra-Low Loss (ULL)** components offer the pinnacle of performance and provide you with the ideal foundation to support high bandwidth, low latency applications.

# Enclosures and Panels | LightVerse®

The Siemon LightVerse fiber optic cabling system includes a range of sleek enclosures and panels available in Core, Plus and Pro options suitable for a wide variety of application needs. Each LightVerse has the ability to support up to 96 fibers within 1U of rack space for all termination methods. Whether its pre-terminated, field terminated, or splice terminated, LightVerse has got you covered.

The range starts with our LightVerse Core model, which offer basic functionality—including fixed fiber termination, and limited configuration options. LightVerse Plus builds upon the functionality of the Core model, introducing additional functionality and moveability with slide out drawers to the product family. The LightVerse Pro level enclosures build further introducing complete modularity, moveability and flexibility, making it ideal for resolving your more complex challenges.



	LightVerse Core	LightVerse Plus	LightVerse Pro
Robust steel construction	●	●	●
Mix and match termination types	●	●	●
Fixed tray	●		
Sliding tray		●	●
96 fibers in 1U	●	●	●
2U/8 slot & 4U/16 slot chassis			●
Integrated label holder		●	●
Front cable managers		●	●
Rear cable management		●	●
Removable top cover	●		●
Enhanced rear cable management system			●
Clear, scratch resistant front door			●
Tamper proof latching front and rear doors			●

### LightVerse Core

Part Number	Description
LVE-1U-MS-C01A	1U, Fixed panel, Modular mount, 4 adapter plate openings

### LightVerse Plus

Part Number	Description
LVE-1U-MD-T01A	1U, Sliding drawer, Modular mount, 4 adapter plate openings

### LightVerse Pro

Part Number	Description
LVE-1U-MD-P01A	1U, Sliding drawer, Modular mount, 4 adapter plate openings
LVE-2U-MD-P01A	2U, Sliding drawer, Modular mount, 8 adapter plate openings
LVE-4U-MD-P01A	4U, Sliding drawer, Modular mount, 16 adapter plate openings

# Enclosures and Panels | LightStack™ UHD

Siemon's LightStack UHD enclosure and panels provide a cost-effective and space-saving solution for ultra high density plug and play fiber applications. Their compact footprints support 144 fibers within 1U, with LC-to-LC and MTP-to-MTP connectivity supported. Both the enclosures and panels provide low loss performance to accommodate a wide range of channel configurations for both multimode and singlemode applications while the simplified, self-contained design optimizes shipping, handling, and installation, especially in space-limited environments.

Optional rear and front cable managers are available for both the enclosures and panels. The front manager is attached by the rack screws while the rear manager has a tool-less connection at the back of the unit. The panels are available with multiple adapter color and MTP® orientation options to support multimode and singlemode applications.

### FHD44 (X) - LS (XX) (X) - (X) B

BASE VERSION	FIBER TYPE	PINNING	POLARITY
E = Base-8 T = Base-12	5V = OM4, XGLO Multimode, Aqua EV = OM4, XGLO Multimode, Violet SM = OS1/OS2, Singlemode	F = Unpinned M = Pinned	1 = Method B1 2 = Method B2 C = Method C

### LightStack UHD LC Fiber Patch Panels

Part Number	Description
FHP44-LSAQ-B	LightStack UHD LC panel, Aqua adapter color, Black panel
FHP44-LSBL-B	LightStack UHD LC panel, Blue adapter color, Black panel
FHP44-LSEV-B	LightStack UHD LC panel, Erika Violet adapter color, Black panel
FHP44-LSGN-B	LightStack UHD LC panel, green adapter color, Black panel

### LightStack UHD MTP® Fiber Patch Panels

Part Number	Description
FHP36-MPBK-B	LightStack UHD MTP panel, Black/opposed adapter color, Black panel
FHP36-MPAQ-B	LightStack UHD MTP panel, Aqua/opposed adapter color, Black panel
FHP36-MPGR-B	LightStack UHD MTP panel, Gray/aligned adapter color, Black panel
FHP36-MPEV-B	LightStack UHD MTP panel, Erika Violet/opposed adapter color, Black panel

### Cable Managers

Part Number	Description
FHD-FCM-1U-01	Front cable manager with door
FHD-RCM-1U-01	Rear cable manager

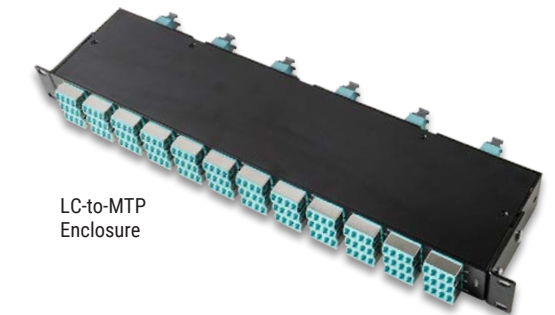

LC-to-MTP Enclosure



MTP-to-MTP Patch Panel

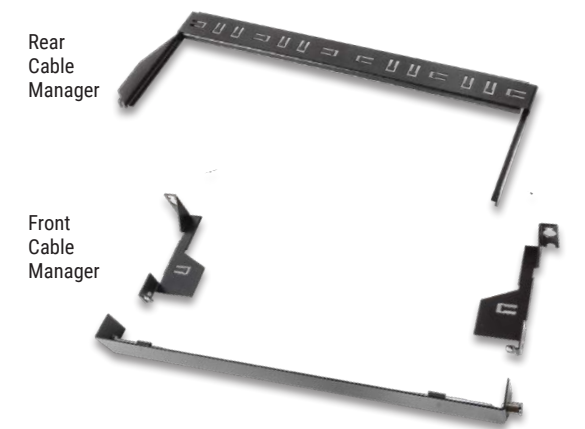

Rear Cable Manager

Front Cable Manager

### OPTICAL PERFORMANCE SPECIFICATIONS

	Multimode	
	Insertion Loss (dB)	Return Loss (dB)
MTP	0.20	20
LC	0.15	30
MTP-TO-LC ENCLOSURE	0.35	20

	Singlemode	
	Insertion Loss (dB)	Return Loss (dB)
MTP	0.60	60
LC	0.40	55
MTP-TO-LC ENCLOSURE	1.00	55

# Modules | LightVerse®

The Siemon LightVerse system includes a wide range of plug and play transition modules which have been designed with the user in mind, combining innovative functionality with the quality and performance users expect from Siemon fiber solutions. This module may also be used as an aggregation/breakout module for network aggregation.

Available in singlemode and multimode fiber options, Base-8 and Base-12 fiber configurations and various connector types, LightVerse modules allow users to seamlessly mix-and-match different types as needed to support their unique application needs.

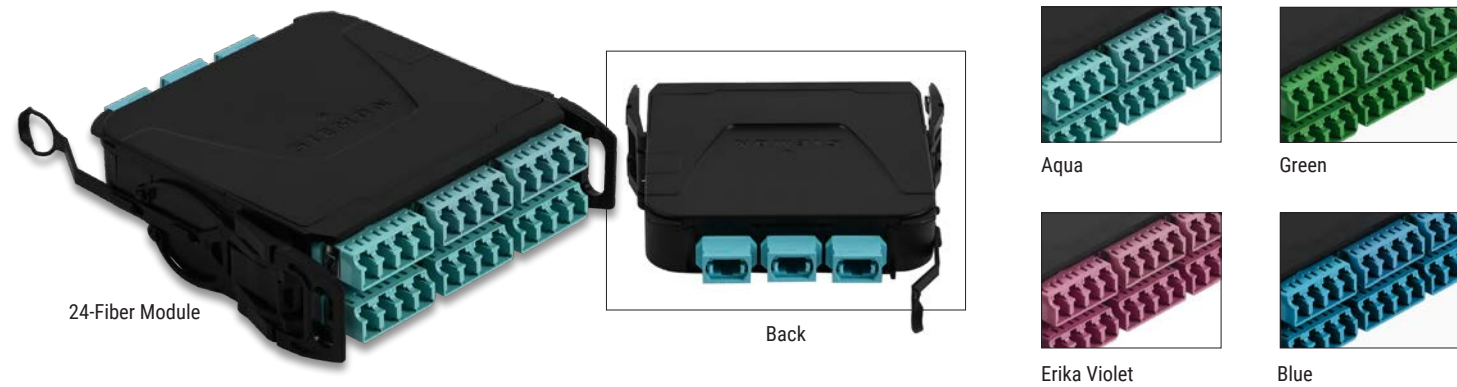

## PERFORMANCE SPECIFICATIONS (STANDARD)

Fiber Type	Max. Insertion Loss (dB)		Min. Return Loss (dB)		Performance Class
	MTP	LC	MTP	LC	
5L-MM 50/125 10G (OM3)	0.40	0.25	20	30	XGLO® 300
5V-MM 50/125 10G (OM4)	0.40	0.25	20	30	XGLO 550
SM-LWP SM (OS1/OS2)	0.60	0.40	60	55 UPC/65 APC	XGLO



\*Optional shuttered LC adapters are also available, featuring a small plastic shutter door that opens upon insertion without touching the connector endface and springs back into the closed position upon removal to ensure protection of empty ports.

## PERFORMANCE SPECIFICATIONS (ULTRA-LOW LOSS)

Fiber Type	Max. Insertion Loss (dB)		Min. Return Loss (dB)		Performance Class
	MTP	LC	MTP	LC	
5L-MM 50/125 10G (OM3)	0.20	0.15	20	30	XGLO 300
5V-MM 50/125 10G (OM4)	0.20	0.15	20	30	XGLO 550
SM-LWP SM (OS1/OS2)	0.30	0.20	60	55 UPC/65 APC	XGLO

## LVM (XX) (X) (X) (XX) (X) - B (X) (X) A

FIBER COUNT	BASE	PINNING	CONNECTOR	MODE	PERFORMANCE	POLARITY
12 = 12 24 = 24	E = Base-8* T = Base-12	F = Unpinned M = Pinned	LC = Non Shuttered LS = Shuttered	L = OM3 (LC/Aqua - MTP/Aqua) V = OM4 (LC/Aqua - MTP/Aqua) E = OM4 (LC/Erika Violet - MTP/ Erika Violet) U = LC/UPC, MTP/APC (LC/Blue - MTP/Black) A = LC/APC, MTP/APC (LC/Green - MTP/Black)	S = Standard Loss L = Ultra-Low Loss	C = Polarity A&C U = U1 Universal Polarity**

\*Base-8 is 24-fibers only. \*\*Universal polarity offered under patent license.

# Adapter Plates | LightVerse®

The Siemon LightVerse system includes a comprehensive range of pass-through adapter plates which have been designed with the user in mind, combining innovative functionality with the quality and performance users expect from Siemon fiber solutions.

Available in singlemode and multimode fiber options and various connector types, LightVerse adapter plates allow users to seamlessly mix-and-match different types as needed to support their unique application needs.

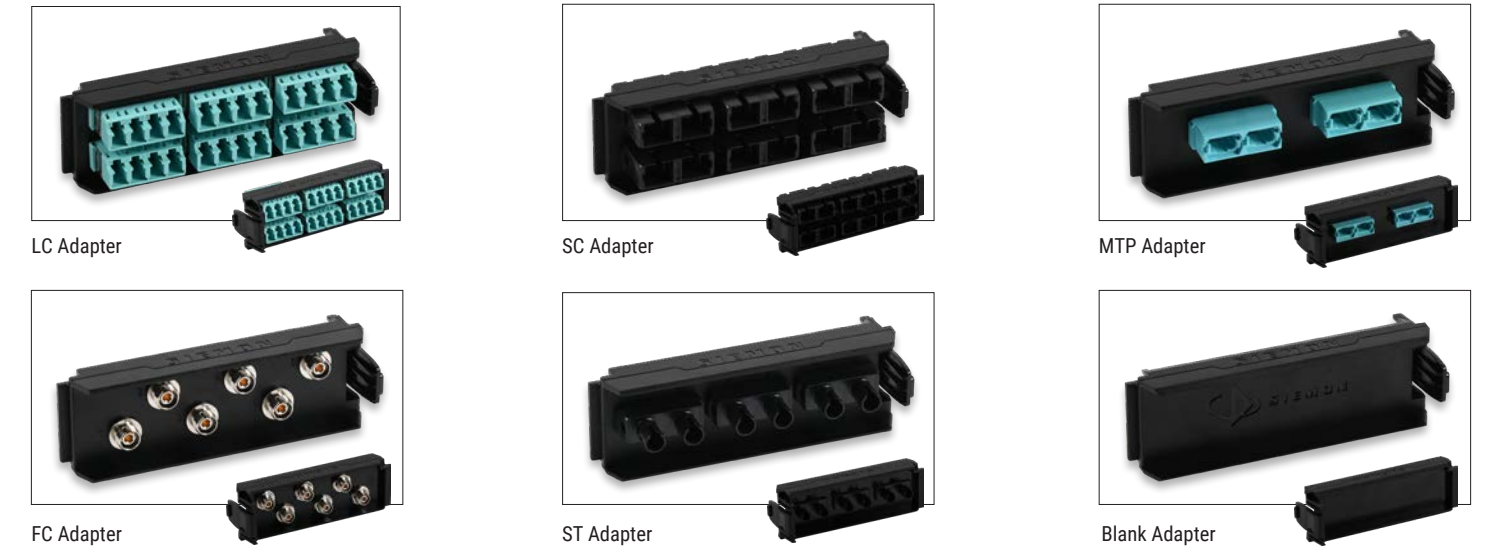

## LightVerse FC Adapter Plate Black with metal sleeve

Part Number	Description
LVA06-FCM-BM-A	MM and SM UPC (Phos. bronze sleeve)

## LightVerse ST Adapter Plate Black with metal sleeve

Part Number	Description
LVA06-STB-BM-A	Black ST adapter (SM/MM)

## LightVerse Blank Adapter Plate

Part Number	Description
LVA-BLANK-01A	Blank adapter plate



\*Optional shuttered LC adapters are also available, featuring a small plastic shutter door that opens upon insertion without touching the connector endface and springs back into the closed position upon removal to ensure protection of empty ports.

## LightVerse LC Adapter Plate Black with ceramic sleeve

LVA (XX) - (XX) (X) - BC - A

FIBER COUNT	CONNECTOR	MODE
12 = 12 16 = 16 24 = 24	LC = Non Shuttered LS = Shuttered	E = Erika Violet Q = Aqua U = Blue A = Green P = Beige

## LightVerse SC Adapter Plate Black with metal sleeve

LVA (XX) - SC (X) - B (X) - A

FIBER COUNT	MODE	SLEEVE
06 = 06 08 = 08 12 = 12	Q = Aqua B = Black (SM/MM)	M = Metal C = Ceramic (Green/APC only)

## LightVerse MTP Adapter Plate Black

LVA (XX) - MP (X) - BN - A

PORTS*	MODE
M1 = 1 Port M2 = 2 Port M4 = 4 Port M6 = 6 Port M8 = 8 Port	B = Black (Type - A, key up to key down) E = Erika Violet (Type - A, key up to key down) Q = Aqua (Type - A, key up to key down) G = Gray (Type - B, key up to key up)

\*Base-8 and Base-12 only. Not to be used with any other MTP connector count.

ENGINEERED FOR EXCELLENCE

BEAUTIFUL BY DESIGN

Siemon's LightVerse® solution is the industry's first truly 400G-ready solution and has been third-party verified by Intertek to its exacting standards.

Available with ultra-low loss connectivity and support for multiple industry recognized polarity schemes, LightVerse modules and adapter plates combine with Siemon's award-winning line of Plug and Play trunks, traditional LC duplex jumpers, and innovative LC BladePatch® fiber jumpers to deliver a complete end-to-end ecosystem that unlocks the potential of your high-density fiber installations in data center and LAN spaces.

Are you looking for industry leading performance as a standard? Think LightVerse.

Discover more at:  
[www.siemon.com/lightverse](http://www.siemon.com/lightverse)



## Trunks | Base-8 MTP-to-MTP

Combining Siemon's reduced-diameter RazorCore™ cable with 8-fiber MTP connectors, Base-8 Plug and Play MTP or MTP® Pro Trunk Assemblies are designed to be quickly routed and connected to Siemon Plug and Play Modules and MTP Adapter Plates. Custom configurable to precise application requirements, these Base-8 assemblies put high-performance, high-density fiber connections exactly where you need them while providing a more efficient migration path to support future high-speed 8-fiber applications.

40G Base-SR4 8-Fiber and  
 100G Base-SR4 8-Fiber MTP  
 (1) 8 strand MTP trunk is used for one link.

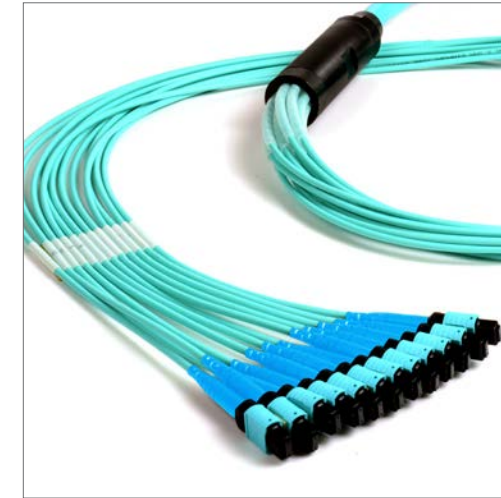
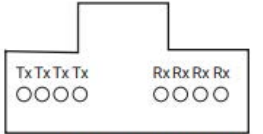

### OPTICAL AND PHYSICAL SPECIFICATIONS

Cable Type	Multimode		Singlemode
	XGLO® 50/125 OM3 (850/1300mm)	XGLO 50/125 OM4 (850/1300mm)	XGLO (1310/1383/1550mm)
FIBER CABLE ATTENUATION, MAX (DB/KM)	3.0/1.0	3.0/1.0	0.4/0.4/0.3*
LED BANDWIDTH, MIN (MHZ/KM)	1500/500	3500/500	N/A
EFFECTIVE MODAL BANDWIDTH, MIN (MHZ/KM)	2000	4700	N/A
CABLE OUTER JACKET, COLOR (PER TIA-598-C)	Aqua	Aqua	Yellow
MAX INSERTION (DB)	0.4 (MTP) 0.2 ULL (MTP)	0.4 (MTP) 0.2 ULL (MTP)	0.6 (MTP) 0.3 ULL (MTP)
MIN RETURN LOSS (DB)	20 (MTP)	20 (MTP)	60 (MTP)

\*XGLO Singlemode fiber meets low water peak specifications per ITU-T G.652.C.

### Base-8 MTP-to-MTP Trunks, 8-Fiber MTP Connectors

G (X) (X to XXX) (X) (XX) (X) (XXX) (X) - (X)

PERFORMANCE	FIBER COUNT	PINNING	FIBER TYPE	JACKET RATING	LENGTH	LENGTH UNIT	POLARITY
R = Standard Loss L = Ultra-Low Loss	8 = 8 16 = 16 24 = 24 32 = 32 48 = 48 72 = 72 96 = 96 144 = 144	F = Unpinned M = Pinned	5L = OM3 XGLO 300 50/125 Multimode, Aqua 5V = OM4 XGLO 550 50/125 Multimode, Aqua EV = OM4, XGLO 550 50/125 Multimode, Erika Violet SM = OS1/OS2 Singlemode, Yellow	P = OFNP L = LSOH (Euroclass Dca) C = LSOH (Euroclass Cca)	Length must be 3 digits Example: 005 = 5m 050 = 50 ft.	F = Feet M = Meter	A = Method A B = Method B C = Method C

### Base-8 MTP-to-MTP Trunks, 8-Fiber MTP Pro Connectors

G (X) P (X to XXX) (X) (X) (X) (X) - (XXX) (X) (X)

CONFIGURATION	FIBER COUNT	FIBER TYPE	JACKET RATING	CONNECTOR "A" PINNING	CONNECTOR "B" PINNING	LENGTH	LENGTH UNIT	POLARITY
R = Standard Loss L = Ultra-Low Loss	8 = 8 16 = 16 24 = 24 32 = 32 48 = 48 72 = 72 96 = 96 E4 = 144	L = OM3, XGLO 300 50/125 Multimode, Aqua V = OM4, XGLO 550 50/125 Multimode, Aqua E = OM4, XGLO 550 50/125 Multimode, Erika Violet A = OS1/OS2, Singlemode, Yellow	P = OFNP L = LSOH (Euroclass Dca) C = LSOH (Euroclass Cca)	F = Unpinned M = Pinned	F = Unpinned M = Pinned	Length must be 3 digits Example: 003 = 3m 010 = 10 ft.	F = Feet M = Meter	A = Method A B = Method B C = Method C

# Trunks | Base-12 MTP-to-MTP

Combining Siemon's reduced-diameter RazorCore™ cable with 12-fiber MTP or MTP® Pro connectors, plug and play reels are designed to be quickly pulled and connected to Siemon plug and play modules and MTP adapter plates. Custom configurable to precise application requirements, these reels efficiently put high-performance, high-density fiber connections exactly where you need them. Extenders offer pinned MTP connectors on one end and unpinned MTP with a MTP adapter on the other to allow field extension of MTP Reels.

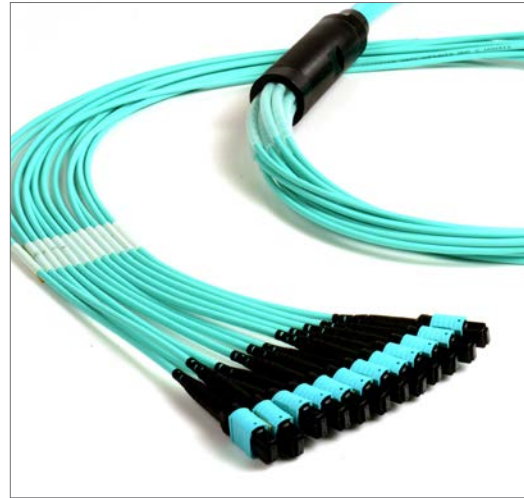

## OPTICAL AND PHYSICAL SPECIFICATIONS

Cable Type	Multimode		Singlemode
	XGLO® OM3 (850/1300nm)	XGLO OM4 (850/1300nm)	XGLO (1310/1383/1550nm)
FIBER CABLE ATTENUATION, MAX (DB/KM)	3.0/1.0	3.0/1.0	0.4/0.4/0.3*
LED BANDWIDTH, MIN (MHZ/KM)	1500/500	3500/500	N/A
EFFECTIVE MODAL BANDWIDTH, MIN (MHZ/KM)	2000	4700	N/A
CABLE OUTER JACKET, COLOR (PER TIA-598-C)	Aqua	Aqua	Yellow
MAX INSERTION (DB)	0.4 (MTP) 0.2 ULL (MTP)	0.4 (MTP) 0.2 ULL (MTP)	0.6 (MTP) 0.3 ULL (MTP)
MIN RETURN LOSS (DB)	20 (MTP)	20 (MTP)	60 (MTP)

\*XGLO Singlemode fiber meets low water peak specifications per ITU-T G.652.C.

### Base-12 MTP-to-MTP Trunks, 12-Fiber MTP Connectors

F (X) (XX or XXX) - (XX) (X) (XXX) (X) - (X)

CONFIGURATION	FIBER COUNT***	FIBER TYPE	JACKET RATING	LENGTH**	LENGTH UNIT	POLARITY METHOD (PER TIA-568-C.0)
R = Standard Loss L = Ultra-Low Loss	12 = 12 24 = 24	5L = OM3, XGLO 300 Multimode, Aqua	P = OFNP L = LSOH (Euroclass Dca)	Length must be 3 digits Example: 003 = 3m 010 = 10 ft.	F = Feet M = Meters	A = Method A B = Method B C = Method C Blank = Fiber Extender (FE and FB)
E* = Standard Loss Extender B* = Ultra-Low Loss Extender	36 = 36 48 = 48 72 = 72 96 = 96 144 = 144	5V = OM4, XGLO 550 Multimode, Aqua EV = OM4, XGLO 550 Multimode, Erika Violet SM = OS1/OS2, Singlemode, Yellow	C = LSOH (Euroclass Cca).			

\*\*Class Cca is available in 8-24 strands.

### Base-12 MTP-to-MTP Trunks, 12-Fiber MTP Pro Connectors

F (X) P (XX or XXX) (X) (X) (X) (X) - (XXX) (X) (X)

CONFIGURATION	FIBER COUNT	FIBER TYPE	JACKET RATING	CONNECTOR "A" PINNING	CONNECTOR "B" PINNING	LENGTH	LENGTH UNIT	POLARITY
R = Standard Loss L = Ultra-Low Loss	12 = 12 24 = 24 48 = 48 72 = 72 96 = 96 E4 = 144	L = OM3, XGLO 300 Multimode, Aqua V = OM4, XGLO 550 Multimode, Aqua E = OM4, XGLO 550 Multimode, Erika Violet A = OS1/OS2, Singlemode, Yellow	P = OFNP L = LSOH (Euroclass Dca) C = LSOH (Euroclass Cca)	F = Unpinned M = Pinned	F = Unpinned M = Pinned	Length must be 3 digits Example: 003 = 3m 010 = 10 ft.	F = Feet M = Meter	A = Method A B = Method B C = Method C

# Trunks | Base-8 MTP-to-LC

Utilizing Siemon's high-quality RazorCore™ cable, Base-8 MTP-to-LC trunks offer a connectivity transition from 8-fiber MTP connectors to duplex LC. Ideal to facilitate interconnects or cross-connects between active equipment, these Base-8 MTP-to-LC assemblies may be implemented using Siemon's MTP-to-MTP adapter plates to provide direct MTP-to-LC patching options over a wide range of distances and infrastructure configurations.

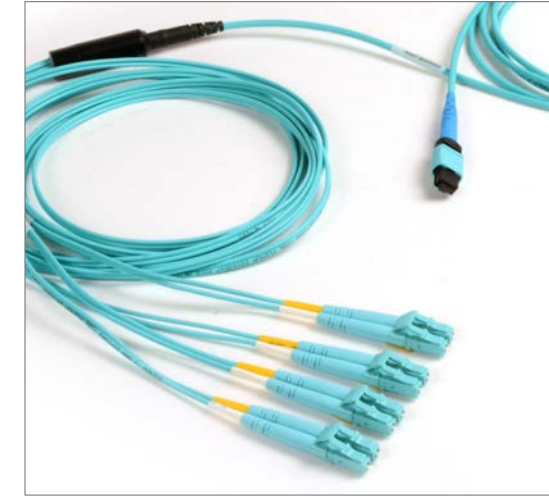

## OPTICAL AND PHYSICAL SPECIFICATIONS

Cable Type	Multimode		Min Return Loss (db)
	XGLO® 50/125 OM3 (850/1300nm)	XGLO 50/125 OM4 (850/1300nm)	XGLO (1310/1383/1550nm)
FIBER CABLE ATTENUATION, MAX (DB/KM)	3.0/1.0	3.0/1.0	0.4/0.4/0.3*
LED BANDWIDTH, MIN (MHZ/KM)	1500/500	3500/500	N/A
EFFECTIVE MODAL BANDWIDTH, MIN (MHZ/KM)	2000	4700	N/A
CABLE OUTER JACKET, COLOR (PER TIA-598-C)	Aqua	Aqua	Yellow
MAX INSERTION (DB)	0.4 (MTP) 0.2 ULL (MTP) 0.25 (LC) 0.15 ULL (LC)	0.4 (MTP) 0.2 ULL (MTP) 0.25 (LC) 0.15 ULL (LC)	0.6 (MTP) 0.3 ULL (MTP) 0.40 (LC) 0.20 ULL (LC UPC) 0.25 ULL (LC APC)
MIN RETURN LOSS (DB)	20 (MTP) 30 (LC)	20 (MTP) 30 (LC)	60 MTP 55 (LC UPC) 65 (LC APC)

\*XGLO Singlemode fiber meets low water peak specifications per ITU-T G.652.C.

### Base-8 MTP-to-LC Trunks

G (X) (X) (X) (XX) (X) (XX) (XX) (XXX) (X)

CONFIGURATION	FIBER COUNT	PULLING EYE	FIBER TYPE	JACKET RATING	PINNING	POLARITY	LENGTH	LENGTH UNIT
R = Standard Loss L = Ultra-Low Loss	B = 8 C = 16 D = 24 E = 32 F = 48 G = 72 H = 96 J = 144	A = MTP Side (> 5m only) C = None	5L = OM3, XGLO 300 Multimode, Aqua 5V = OM4, XGLO 550 Multimode, Aqua EV = OM4, XGLO 550 Multimode, Erika Violet SM = OS2, XGLO Singlemode, Yellow	P = OFNP L = LSOH (Euroclass Dca)	F = Unpinned M = Pinned	LC = Reverse Fiber Position (RFP) CL = Continuous Fiber Position (CFP)	Length must be 3 digits Example: 003 = 3m 010 = 10 ft.	F = Feet M = Meter

\*Minimum order length is 1 meter (3.28 ft.). Order length is measured connector tip to connector tip. Trunks greater than 1 meter (3.28 ft.) have breakout length of 1 meter (3.28 ft.). 1 meter (3.28 ft.) trunks have a 50cm (1.64 ft.) breakout length.

\*\*Only trunk lengths greater than 5 meters (16FT) come with a pulling eye.

# Trunks | Base-12 MTP-to-LC

Utilizing high quality Siemon RazorCore™ cable, MTP-to-LC trunks offer a connectivity transition from 12-fiber MTP or MTP® Pro connectors to duplex LC connectors. These may be implemented using Siemon's MTP-to-MTP adapter plates to provide direct MTP-to-LC patching options over a wide range of distances and infrastructure configurations.



## OPTICAL AND PHYSICAL SPECIFICATIONS

Cable Type	Multimode		Singlemode
	XGLO® 50/125 OM3 (850/1300nm)	XGLO 50/125 OM4 (850/1300nm)	XGLO (1310/1383/1550nm)
<b>FIBER CABLE ATTENUATION, MAX (DB/KM)</b>	3.0/1.0	3.0/1.0	0.4/0.4/0.3*
<b>LED BANDWIDTH, MIN (MHZ/KM)</b>	1500/500	3500/500	N/A
<b>EFFECTIVE MODAL BANDWIDTH, MIN (MHZ/KM)</b>	2000	4700	N/A
<b>CABLE OUTER JACKET, COLOR (PER TIA-598-C)</b>	Aqua	Aqua	Yellow
<b>MAX INSERTION (DB)</b>	0.4 (MTP) 0.2 ULL (MTP) 0.25 (LC) 0.15 ULL (LC)	0.4 (MTP) 0.2 ULL (MTP) 0.25 (LC) 0.15 ULL (LC)	0.6 (MTP) 0.3 ULL (MTP) 0.40 (LC) 0.20 ULL (LC UPC) 0.25 ULL (LC APC)
<b>MIN RETURN LOSS (DB)</b>	20 (MTP) 30 (LC)	20 (MTP) 30 (LC)	60 MTP 55 (LC UPC) 65 (LC APC)

\*XGLO Singlemode fiber meets low water peak specifications per ITU-T G.652.C.

## Base-12 MTP-to-LC Trunks

T (X) (X) (X) (XX) (X) (XX) LC (XXX) (X)

CONFIGURATION	FIBER COUNT	PULLING EYE	FIBER TYPE	JACKET RATING	PINNING	LENGTH	LENGTH UNIT
F = Standard Loss L = Ultra-Low Loss	B = 12 C = 24 E = 36 F = 48 G = 72 H = 96 J = 144	A = Side A B = Side B C = None	5L = OM3, XGLO 300 50/125 Multimode, Aqua 5V = OM4, XGLO 550 50/125 Multimode, Aqua EV = OM4, XGLO 550 50/125 Multimode, Erika Violet SM = OS1/OS2, Singlemode Yellow	P = OFNP L = LSOH (Euroclass Dca) C = LSOH (Euroclass Cca)	MF = Unpinned Standard MM = Pinned Standard PF = MTP Pro Unpinned PM = MTP Pro Pinned	Length must be 3 digits Example: 003 = 3m 010 = 10 ft.	F = Feet M = Meter

# Fiber Jumpers | LC BladePatch®

Siemon's LC BladePatch uniboot duplex jumper offers an exceptional solution for high-density fiber optic patching environments. It delivers the performance, functionality and quality you require to effectively manage your high-speed networks and is ideal for patching high density blade servers, patch panels and equipment.

LC BladePatch includes a revolutionary push-pull boot, providing easy access and removal in tight-fitting areas. Siemon's UniClick™ uniboot technology features a smaller footprint, one-piece body with an integrated switch to enable faster and easier polarity change using the innovative rotating latches. LC BladePatch jumpers use multimode and singlemode bend insensitive glass, ensuring enhanced performance, as well as a smaller diameter uni-tube cable design which reduces cable pathway congestion, improving air flow and increasing energy efficiency while simplifying overall cable management.



## PERFORMANCE SPECIFICATIONS – ULTRA-LOW LOSS

	Multimode						Singlemode	
	OM3 50/125µm		OM4 50/125µm				UPC - OS1/OS2	APC - OS1/OS2
<b>WAVELENGTH (NM)</b>	850	1300	850*	850	1300	850*	1310/1550nm	1310/1550nm
<b>MIN. CABLE BANDWIDTH (MHZ-KM)</b>	1500 (OFL)	500 (OFL)	2000 (EMB)	3500 (OFL)	500 (OFL)	4700 (EMB)	N/A	N/A
<b>MAX. INSERTION LOSS (DB)</b>	0.15 (0.10 Typical)			0.15 (0.10 Typical)			0.20 (0.10 Typical)	0.25 (0.10 Typical)
<b>MIN. RETURN LOSS (DB)</b>	30 (35 Typical)			30 (35 Typical)			55 (60 Typical)	65 (70 Typical)

\*Laser Bandwidth.

### Polarity

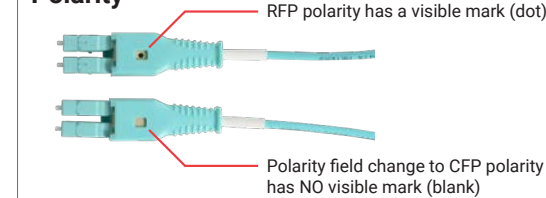

### RFP (Reverse Fiber Position)

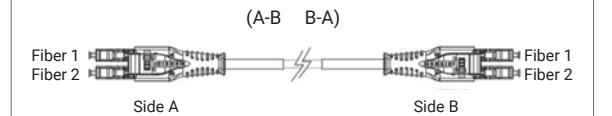

## LC BladePatch (RFP Polarity)

LBP - (XX) (X) (XX) (X) (XX) - (XXX) (XX) (X)

SIDE A - CONNECTOR	SIDE A - MODE/PERFORMANCE	SIDE B - CONNECTOR	SIDE B - MODE/PERFORMANCE	FIBER TYPE	LENGTH	JACKET RATING/COLOR	PACKAGE
LC = LC	Blank = Multimode U = UPC Singlemode A = APC Singlemode	LC = LC	Blank = Multimode U = UPC Singlemode A = APC Singlemode	5L = OM3 XGLO 300 50/125 Multimode 5V = OM4 XGLO 550 50/125 Multimode L = OS1/OS2 Singlemode	Length must be 3 digits Example: 003 = 3m 010 = 10 ft	Blank = Riser (OFNR) Yellow cable, Blue UPC, Green APC connectivity (OS1/OS2) P = Plenum (OFNP) Yellow cable, Blue UPC, Green APC connectivity (OS1/OS2) H = LSOH (IEC 60332-3C) Yellow cable, Blue UPC, Green APC connectivity (OS1/OS2) AQ = Riser (OFNR) Aqua cable & connectivity (OM3,OM4) AP = Plenum (OFNP) Aqua cable & connectivity (OM3, OM4) AH = LSOH (IEC 60332-3C) Aqua cable & connectivity (OM3, OM4) EQ = Riser (OFNR) Erika Violet cable & connectivity (OM4 only) EP = Plenum (OFNP) Erika Violet cable & connectivity (OM4 only) EH = LSOH (IEC 60332-3C) Erika Violet cable & connectivity (OM4 only)	Blank = Non Bulk B = Bulk**

\*\*Bulk pack available in lengths up to 5 meters (16.4 ft.) or less. Remove dashes "-" and add "B" to the end of the part number for bulk pack of 100 jumpers (10 per bag).



# Fiber Jumpers | Base-8 MTP-to-LC

Utilizing Siemon's high quality RazorCore™ fiber cable and our innovative LC BladePatch® connectors, these cords are ideal for supporting interconnects or cross-connects between active equipment, these Base-8 MTP-to-LC BladePatch equipment cords may be implemented using Siemon's MTP-to-MTP adapter plates to provide direct MTP-to-LC patching options over a wide range of distances and infrastructure configurations. They can also be used for connection to active equipment with LC ports used in aggregation of multiple 10G ports to one 40G port.

## OPTICAL AND PHYSICAL SPECIFICATIONS

Cable Type	Multimode		Singlemode
	XGLO® 50/125 OM3 (850/1300mm)	XGLO 50/125 OM4 (850/1300mm)	XGLO (1310/1383/1550nm)
<b>FIBER CABLE ATTENUATION, MAX (DB/KM)</b>	3.0/1.0	3.0/1.0	0.4/0.4/0.3*
<b>LED BANDWIDTH, MIN (MHZ/KM)</b>	1500/500	3500/500	N/A
<b>EFFECTIVE MODAL BANDWIDTH, MIN (MHZ/KM)</b>	2000	4700	N/A
<b>CABLE OUTER JACKET, COLOR (PER TIA-598-C)</b>	Aqua	Aqua	Yellow
<b>MAX INSERTION (DB)</b>	0.4 (MTP) 0.2 ULL (MTP) 0.25 (LC) 0.15 ULL (LC)	0.4 (MTP) 0.2 ULL (MTP) 0.25 (LC) 0.15 ULL (LC)	0.6 (MTP) 0.3 ULL (MTP) 0.40 (LC) 0.20 ULL (LC UPC) 0.25 ULL (LC APC)
<b>MIN RETURN LOSS (DB)</b>	20 (MTP) 30 (LC)	20 (MTP) 30 (LC)	60 MTP 55 (LC UPC) 65 (LC APC)

\*XGLO Singlemode fiber meets low water peak specifications per ITU-T G.652.C.

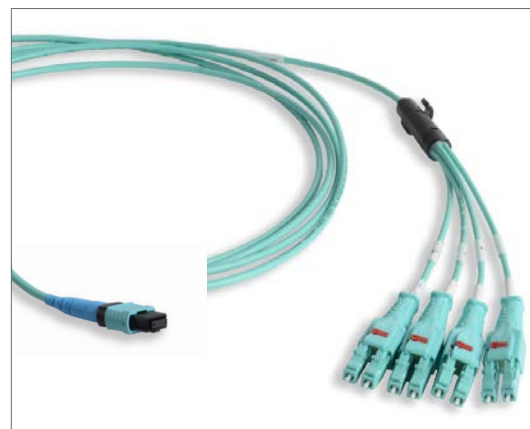

# Fiber Jumpers | Base-12 MTP-to-LC

Utilizing high quality Siemon RazorCore™ cable, Base-12 MTP-to-LC BladePatch® cords offer a connectivity transition from one 12-fiber MTP or MTP Pro connector to six duplex LC connectors. The LC BladePatch connector features UniClick™ technology to easily release the boot to change polarity and a unique push-pull boot to control the latch, enabling easy access and removal in tight-fitting areas. Ideal to facilitate interconnects or cross connects between active equipment, these Base-12 MTP-to-LC BladePatch equipment cords may be implemented using Siemon's MTP-to-MTP Adapter Plates to provide direct MTP-to-LC patching options over a wide range of distances and infrastructure configurations. These trunks are also available in specific staggered lengths for active equipment including NEXUS, Cisco MDS and Brocade.

## OPTICAL AND PHYSICAL SPECIFICATIONS

Cable Type	Multimode		Min. Return Loss (db)
	XGLO® 50/125 OM3 (850/1300mm)	XGLO 50/125 OM4 (850/1300mm)	XGLO (1310/1383/1550mm)
<b>FIBER CABLE ATTENUATION, MAX (DB/KM)</b>	3.0/1.0	3.0/1.0	0.4/0.4/0.3*
<b>LED BANDWIDTH, MIN (MHZ/KM)</b>	1500/500	3500/500	N/A
<b>EFFECTIVE MODAL BANDWIDTH, MIN (MHZ/KM)</b>	2000	4700	N/A
<b>CABLE OUTER JACKET, COLOR (PER TIA-598-C)</b>	Aqua	Aqua	Yellow
<b>MAX INSERTION (DB)</b>	0.4 (MTP) 0.2 ULL (MTP) 0.25 (LC) 0.15 ULL (LC)	0.4 (MTP) 0.2 ULL (MTP) 0.25 (LC) 0.15 ULL (LC)	0.6 (MTP) 0.3 ULL (MTP) 0.40 (LC) 0.20 ULL (LC UPC) 0.25 ULL (LC APC)
<b>MIN RETURN LOSS (DB)</b>	20 (MTP) 30 (LC)	20 (MTP) 30 (LC)	60 MTP 55 (LC UPC) 65 (LC APC)

\*XGLO Singlemode fiber meets low water peak specifications per ITU-T G.652.C

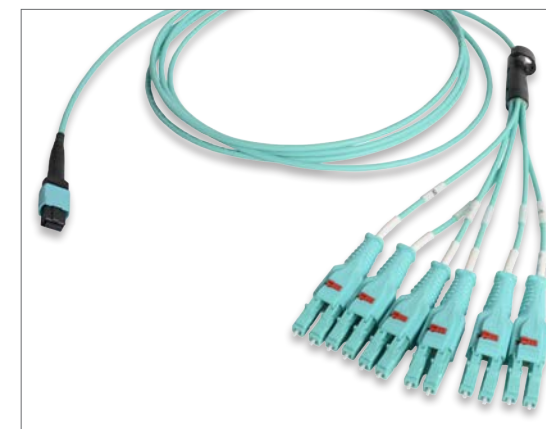

## Base-8 MTP®-to-LC BladePatch Hybrid Fiber Jumpers

T (X) 2 (X) (X) (X) (X) (X) (X) (XX) (XXX) (X)

PERFORMANCE	FIBER COUNT	PULLING EYE OPTION	FIBER TYPE	JACKET RATING	PINNING	STAGGER TYPE	LC BP CONNECTOR	LENGTH	LENGTH UNIT
F = Standard Loss (SM only) L = Ultra-Low Loss (OM3/OM4 only)	N = 8 Strand	A = MTP Side (for lengths >5m only) C = None	L = OM3, XGLO 300 50/125 Multimode, Aqua V = OM4, XGLO 550 50/125 Multimode, Aqua E = OM4, XGLO 550 50/125 Multimode Erika Violet A = OS1/OS2, Singlemode, Yellow	P = OFNP (Euroclass Dca) L = LSOH (Euroclass Cca)	F = Unpinned M = Pinned	1 = No Stagger	LB = Reverse Fiber Position (RFP) BL = Continuous Fiber Position (CFP)	Length must be 3 digits Example: 003 = 3m 010 = 10 ft.	F = Feet M = Meters

\*Minimum order length is 1 meter (3.28 ft.). Order length is measured connector tip to connector tip. Only trunk lengths greater than 5 meters (16FT) come with a pulling eye.

## Base-12 MTP-to-LC BladePatch Hybrid Fiber Jumpers

T (X) (X) B (X) (X) (X) (X) (X) (XX) (XXX) (X)

PERFORMANCE	CONNECTOR OPTION	PULLING EYE OPTION	FIBER TYPE	JACKET RATING	PINNING	STAGGER TYPE	LC BP CONNECTOR	LENGTH	LENGTH UNIT
F = Standard Loss (SM only) L = Ultra-Low Loss (OM3/OM4 only)	2 = Standard MTP P = MTP Pro	A = MTP Side (for lengths >5m only) C = None	L = OM3, XGLO 300 50/125 Multimode Aqua V = OM4, XGLO 550 50/125 Multimode E = OM4, XGLO 550 50/125 Multimode Erika Violet A = OS1/OS2, Singlemode	P = OFNP (Euroclass Dca) L = LSOH (Euroclass Cca)	F = Unpinned M = Pinned	1 = No Stagger 2 = Cisco 9512 & 9412 3 = Cisco NEXUS 4 = Brocade	LB = Reverse Fiber Position (RFP) BL = Continuous Fiber Position (CFP)	Length must be 3 digits Example: 003 = 3m 010 = 10 ft.	F = Feet M = Meters

\*Minimum order length is 1 meter (3.28 ft.). Order length is measured connector tip to connector tip. Only trunk lengths greater than 5 meters (16FT) come with a pulling eye.

# Fiber Jumpers | Base-8 MTP® Pro-to-MTP Pro

Siemon's Base-8 MTP Pro jumpers are used to connect the MTP trunk backbone to the active equipment. The 8-fiber design ensures 100% utilization of fiber in 8-fiber 40/100G applications, while the compact design of the MTP footprint and Siemon's 2mm diameter RazorCore™ cable achieves greater connectivity access, reduction in cable pathway congestion and improved airflow.



## OPTICAL AND PHYSICAL SPECIFICATIONS

Cable Type	Multimode		Singlemode
	XGLO® OM3 (850/1300nm)	XGLO OM4 (850/1300nm)	XGLO (1310/1383/1550nm)
FIBER CABLE ATTENUATION, MAX (DB/KM)	3.0/1.0	3.0/1.0	0.4/0.4/0.3*
LED BANDWIDTH, MIN (MHZ/KM)	1500/500	3500/500	N/A
EFFECTIVE MODAL BANDWIDTH, MIN (MHZ/KM)	2000	4700	N/A
CABLE OUTER JACKET, COLOR (PER TIA-598-C)	Aqua	Aqua	Yellow
MAX INSERTION (DB)	0.4 (MTP) 0.2 ULL (MTP)	0.4 (MTP) 0.2 ULL (MTP)	0.6 (MTP) 0.3 ULL (MTP)
MIN RETURN LOSS (DB)	20 (MTP)	20 (MTP)	60 (MTP)

\*XGLO Singlemode fiber meets low water peak specifications per ITU-T G.652.C.

# Fiber Jumpers | Base-12 MTP® Pro-to-MTP Pro

Siemon's Base-12 MTP Pro jumpers are used to connect the MTP trunk backbone to the active equipment. The compact design of the MTP footprint and Siemon's 2mm diameter RazorCore™ cable achieves greater connectivity access, reduction in cable pathway congestion and improved airflow around the active equipment.

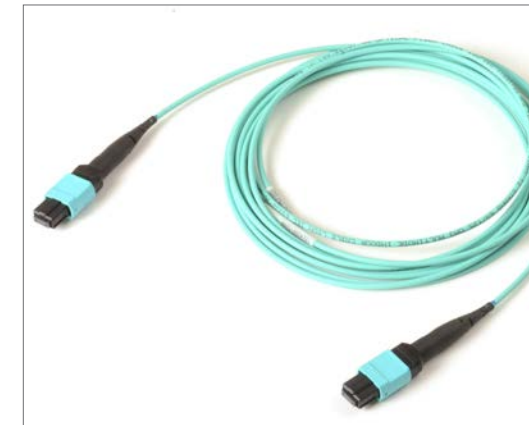

## OPTICAL AND PHYSICAL SPECIFICATIONS

Cable Type	Multimode		Singlemode
	XGLO® OM3 (850/1300nm)	XGLO OM4 (850/1300nm)	XGLO (1310/1383/1550nm)
FIBER CABLE ATTENUATION, MAX (DB/KM)	3.0/1.0	3.0/1.0	0.4/0.4/0.3*
LED BANDWIDTH, MIN (MHZ/KM)	1500/500	3500/500	N/A
EFFECTIVE MODAL BANDWIDTH, MIN (MHZ/KM)	2000	4700	N/A
CABLE OUTER JACKET, COLOR (PER TIA-598-C)	Aqua	Aqua	Yellow
MAX INSERTION (DB)	0.4 (MTP) 0.2 ULL (MTP)	0.4 (MTP) 0.2 ULL (MTP)	0.6 (MTP) 0.3 ULL (MTP)
MIN RETURN LOSS (DB)	20 (MTP)	20 (MTP)	60 (MTP)

\*XGLO Singlemode fiber meets low water peak specifications per ITU-T G.652.C.

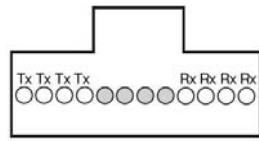

40G BASE-SR4 8-Fiber and 100G BASE-SR4 8-Fiber MTP

(1) 8 strand MTP trunk is used for one link

## MTP Pro Activation Tool and PIN Exchangers

Part Number	Description
FT-MP-AT	Field termination, MTP Pro Activation tool
FT-MP-PE-SME	Field termination, MTP Pro, Pin exchanger with SM elite pins
FT-MP-PE-MME	Field termination, MTP Pro, Pin exchanger with MM elite pins

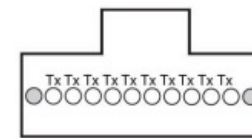

100G Base-SR10, 2 x 12-Fiber MTPs

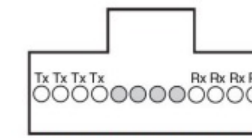

40G Base-SR4, 8-Fiber MTP with the 40G option (1) 12 strand MTP trunk is used for one link.

## MTP Pro Activation Tool and PIN Exchangers

Part Number	Description
FT-MP-AT	Field termination, MTP Pro Activation tool
FT-MP-PE-SME	Field termination, MTP Pro, Pin exchanger with SM elite pins
FT-MP-PE-MME	Field termination, MTP Pro, Pin exchanger with MM elite pins

## Base-8 MTP Pro Fiber Jumpers

GJ (X) P (X) (X) (X) (X) - (XXX) (X) - (X)

PERFORMANCE	FIBER TYPE	JACKET RATING	PINNING SIDE A	PINNING SIDE B	LENGTH	LENGTH UNIT	POLARITY
S = Standard Loss L = Ultra-Low Loss	L = OM3, XGLO 300 50/125 Multimode, Aqua V = OM4, XGLO 550 50/125 Multimode, Aqua E = OM4, XGLO 550 50/125 Multimode, Erika Violet A = OS1/OS2, Singlemode, Yellow	P = OFNP L = LSOH	F = Unpinned M = Pinned	F = Unpinned M = Pinned	Length must be 3 digits Example: 003 = 3m 010 = 10 ft.	F = Feet M = Meter	A = Method A B = Method B C = Method C

## Base-12 MTP Pro Fiber Jumpers

MJ (X) P (X) (X) (X) (X) - (XXX) (X) - (X)

SIDE A MTP	FIBER TYPE	JACKET RATING	PINNING SIDE A	PINNING SIDE B	LENGTH	LENGTH UNIT	POLARITY
S = Standard Loss L = Ultra-Low Loss	L = OM3, XGLO 300 50/125 Multimode, Aqua V = OM4, XGLO 550 50/125 Multimode, Aqua E = OM4, XGLO 550 50/125 Multimode, Erika Violet A = OS1/OS2, Singlemode, Yellow	P = OFNP L = LSOH	F = Unpinned M = Pinned	F = Unpinned M = Pinned	Length must be 3 digits Example: 003 = 3m 010 = 10 ft.	F = Feet M = Meter	A = Method A B = Method B C = Method C

# Conversion Cords | Base-12-to-Base-8

Siemon's high-performance equipment conversion cords ensure 100% fiber utilization in your high-speed applications. Multiple versions of these conversion cords are available, including transitioning (2) 12-fiber MTP connectivity from the backbone trunk to (3) 8-fiber MTP connectors, and transitioning (2) 12-fiber MTP-to-MTP trunks from the backbone to (1) 24-fiber MTP connector to connect to the active equipment.

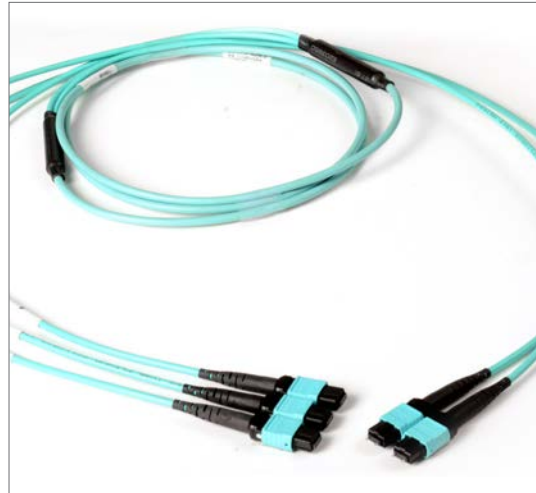

## OPTICAL AND PHYSICAL SPECIFICATIONS

Cable Type	Multimode		Singlemode
	XGLO® OM3 (850/1300nm)	XGLO OM4 (850/1300nm)	XGLO (1310/1383/1550nm)
FIBER CABLE ATTENUATION, MAX (DB/KM)	3.0/1.0	3.0/1.0	0.4/0.4/0.3*
LED BANDWIDTH, MIN (MHZ/KM)	1500/500	3500/500	N/A
EFFECTIVE MODAL BANDWIDTH, MIN (MHZ/KM)	2000	4700	N/A
CABLE OUTER JACKET, COLOR (PER TIA-598-C)	Aqua	Aqua	Yellow
MAX INSERTION (DB)	0.4 (MTP) 0.2 ULL (MTP)	0.4 (MTP) 0.2 ULL (MTP)	0.6 (MTP) 0.3 ULL (MTP)
MIN RETURN LOSS (DB)	20 (MTP)	20 (MTP)	60 (MTP)

\*XGLO Singlemode fiber meets low water peak specifications per ITU-T G.652.C.

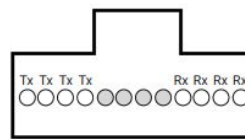

**40G Base-SR4,  
8-Fiber MTP**  
with the 40G option (1) 12 strand MTP trunk is used for one link.

### Base-12-to-Base-8 Conversion Cords

YW (XX) (XX) (XX) (X) (XXX) (X) (X) (X)

PINNING SIDE A MTP (8 CORE)	PINNING SIDE B MTP (12 CORE)	FIBER TYPE	JACKET RATING	LENGTH*	LENGTH UNIT	POLARITY METHOD	PERFORMANCE
MF = Unpinned MM = Pinned	MF = Unpinned MM = Pinned	5L = OM3 XGLO 300 50/125 Multimode 5V = OM4 XGLO 550 50/125 Multimode EV = OM4 XGLO 550 50/125 Multimode, Erika Violet	P = OFNP L = LSOH	Length must be 3 digits Example: 003 = 3m 010 = 10 ft	F = Feet M = Meter	B = Method B C = Method C	L = Ultra-Low Loss Blank = Standard Loss

# Conversion Cords | Base-12-to-Base-24

Siemon's high-performance equipment conversion cords ensure 100% fiber utilization in your high-speed applications. Multiple versions of these conversion cords are available, including transitioning (2) 12-fiber MTP connectivity from the backbone trunk to (3) 8-fiber MTP connectors, and transitioning (2) 12-fiber MTP-to-MTP trunks from the backbone to (1) 24-fiber MTP connector to connect to the active equipment.



## OPTICAL AND PHYSICAL SPECIFICATIONS

Cable Type	Multimode		Singlemode
	XGLO® OM3 (850/1300nm)	XGLO OM4 (850/1300nm)	XGLO (1310/1383/1550nm)
FIBER CABLE ATTENUATION, MAX (DB/KM)	3.0/1.0	3.0/1.0	0.4/0.4/0.3*
LED BANDWIDTH, MIN (MHZ/KM)	1500/500	3500/500	N/A
EFFECTIVE MODAL BANDWIDTH, MIN (MHZ/KM)	2000	4700	N/A
CABLE OUTER JACKET, COLOR (PER TIA-598-C)	Aqua	Aqua	Yellow
MAX INSERTION (DB)	0.4 (MTP) 0.2 ULL (MTP)	0.4 (MTP) 0.2 ULL (MTP)	0.6 (MTP) 0.3 ULL (MTP)
MIN RETURN LOSS (DB)	20 (MTP)	20 (MTP)	60 (MTP)

\*XGLO Singlemode fiber meets low water peak specifications per ITU-T G.652.C.

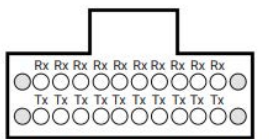

**100G Base-SR10,  
1 x 24-Fiber MTPs**  
with the 100G option (1) 24 strand MTP trunks are used for one link.

### Base-12-to-Base-24 Conversion Cords

YJ (XX) (XX) (XX) (X) (XXX) (X) (X) (X)

PINNING SIDE A MTP (24 CORE)	PINNING SIDE B MTP (12 CORE)	FIBER TYPE	JACKET RATING	LENGTH*	LENGTH UNIT	POLARITY METHOD	PERFORMANCE
MF = Unpinned	MF = Unpinned	5L = OM3 XGLO 300 50/125 Multimode, 5V = OM4 XGLO 550 50/125 Multimode, EV = OM4 XGLO 550 50/125 Multimode, Erika Violet SM = OS2 XGLO Singlemode, Yellow	P = OFNP L = LSOH	Length must be 3 digits Example: 003 = 3m 010 = 10 ft	F = Feet M = Meter	B = Method B C = Method C	L = Ultra-Low Loss Blank = Standard Loss

# How Can you Master Polarity?

Following the release of the ANSI/TIA-568.3-E, *Optical Fiber Cabling and Components Standard*, users have seen the addition of two new connectivity (polarity) methods for array (MPO)-based duplex applications. The revision also introduced revised guidance on pinning of connectors to better support future transition to end-to-end array systems.

Prior to the release of this revision of the standard, connectivity methods for array-based duplex applications were limited to Methods A, B & C – each having its own strengths and weaknesses. ANSI/TIA-568.3-E introduced two new “universal” methods: U1 and U2. The advantage of these new methods is having the commonality components of Method B without the need for unique MTP-to-LC modules on each end. Customers can now use the same MPO-to-LC modules and duplex patch cords on either end of the channel in conjunction with a Type-B trunk – thus simplifying deployments.

Methods U1 and U2 both use Type-B array trunks and A-to-B duplex patch cords. Where they differ is Method U1 uses Type-A (Key-Up to Key-Down) array adapters and Type-U1 fiber transitions which Method U2 uses Type-B (Key-Up to Key-Up) array adapters and Type-U2 fiber transitions as show below in Table 1 and Figure 1:

Connectivity Method	Array Trunk Cable	Array Adapter	Fiber Transition	Duplex Patch Cord
U1	Type-B	Type-A	Type-U1	A-to-B
U2		Type-B	Type-U2	

**Table 1:** New Duplex Connectivity Methods

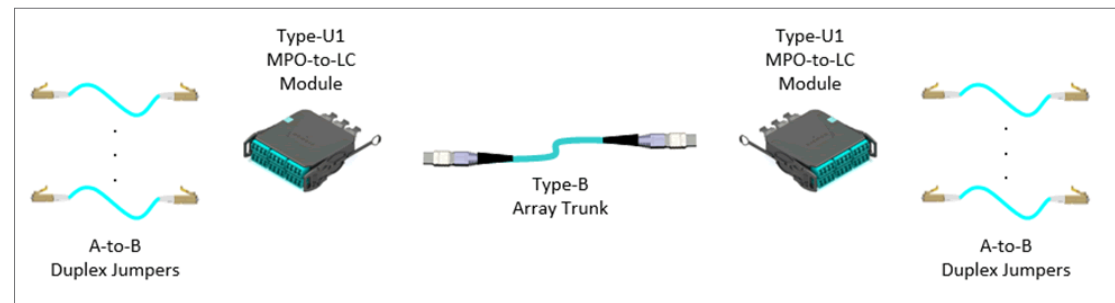

**Figure 1:** Connectivity Method 1

The key advantage of Method U1 vs Method U2 is that the use of Type-A adapters enables support of both multimode and singlemode applications as standard singlemode MPO connectors utilize opposing angled physical contact (APC) end faces which are necessary to provide the more stringent return loss requirements of singlemode applications.

Additionally, Method U1 MPO-to-LC modules are ideal for use as a breakout or aggregation module for optical transceiver applications as shown below in Figure 2. *For more information, please refer to Siemon’s Tech Brief 40 to 400G Optical Transceiver Breakout Links.*

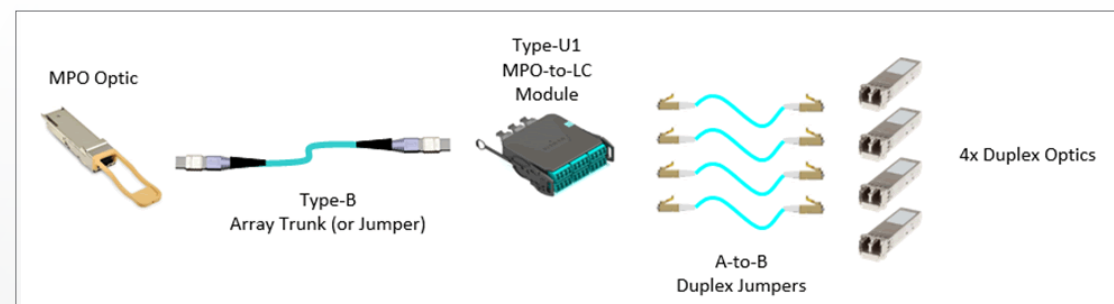

**Figure 2:** Breakout Application via Type-U1 MPO-to-LC Module

Additional MPO connector pinning guidance was also introduced in this new revision of the standard to better enable future transition of an array-based duplex system to an end-to-end array system. When mating MPO connectors – which use alignment pins – it is a requirement that one plug is pinned and the other plug is unpinned. As MPO active equipment ports are pinned, they accept only unpinned plugs.

Therefore, an optimally designed array-based duplex system intended to support a future transition to an end-to-end array system should specify the following as illustrated in Figures 3 and 4:

*Array trunk cables should be pinned on both ends.*

*MPO connectors within the MPO-to-LC modules should be unpinned.*

*Future array patch cords connecting MPO active equipment ports to the array cabling should be unpinned on both ends*

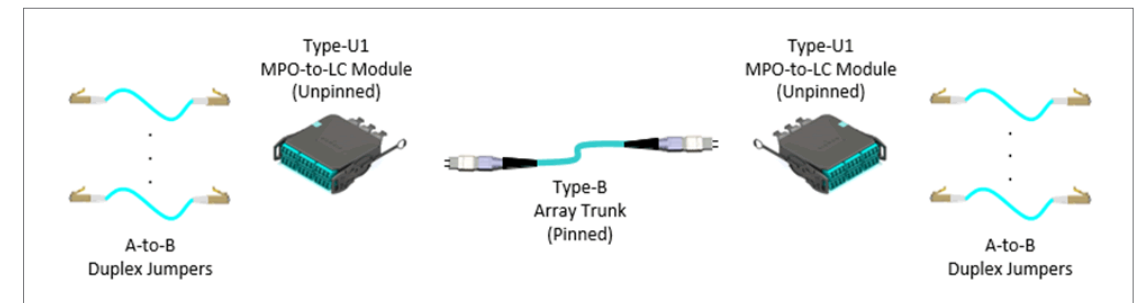

**Figure 3:** Recommended Array-based Duplex System Pinning

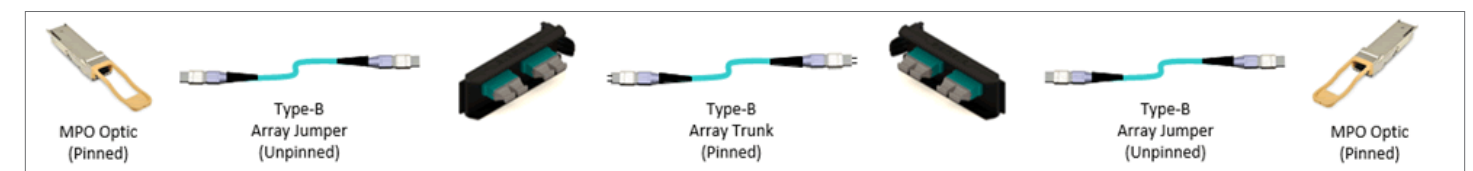
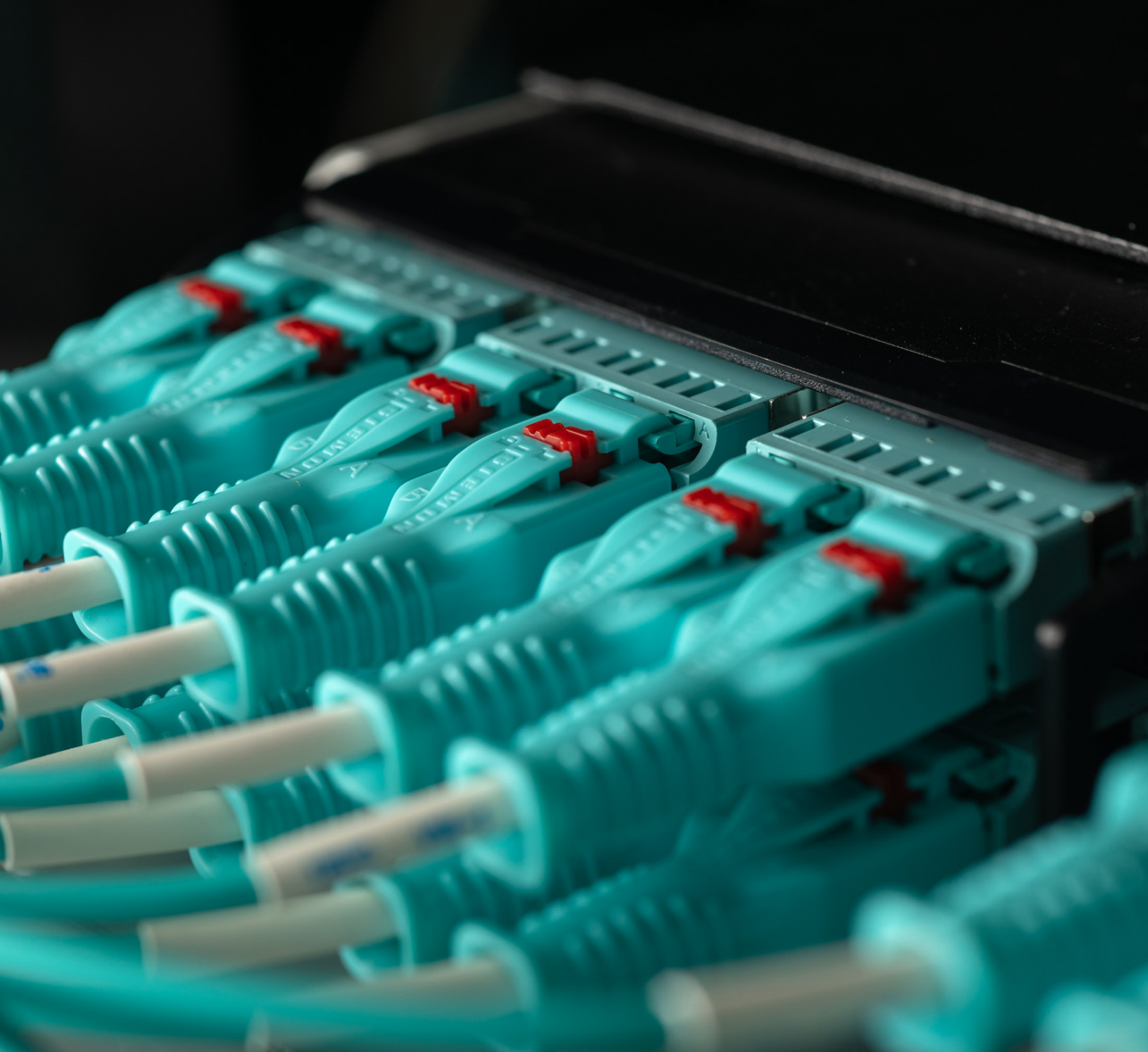

**Figure 4:** Recommended Array System Pinning

Siemon’s LightVerse® fiber optic system offers Type-U1 MPO-to-LC modules with unpinned MPO connectors in both Base-8 and Base-12 as the standard offering. Siemon recommends the use of pinned array trunks ensuring the simplest design and implementation of array-based duplex systems, breakout applications and future transition to end-to-end array systems.

## Remove the Complexity

If you would like any additional information or support on correctly designing and configuring your plug and play system for your application requirements please reach out and organize a Discovery Session with a member of our Technical Team today.



## START YOUR PLUG AND PLAY JOURNEY TODAY!



For more information visit:  
[www.siemon.com](http://www.siemon.com)



Find your local Siemon distributor:  
[go.siemon.com/distributor](http://go.siemon.com/distributor)



24/7 Customer Support:  
[customer\\_service@siemon.com](mailto:customer_service@siemon.com)